

E-series

4x4

Articulated Dump Trucks

B30E | B45E | B60E • PIN3

Stage V Certified



- Same payload as 6x6 models
- Smaller turning circle than similar sized 6x6 model
- Highly manoeuvrable in tight spaces
- No tyre scuff means less tyre and road surface damage

BELL

The All-Wheel Drive advantage

The Bell 4x4 range, comprising a 30-ton, 45-ton and 60-ton model, offers customers the same tonnage as our traditional Articulated Dump Trucks (ADTs), at a related lower cost per tonne while still offering off-road capabilities that non-ADT solutions cannot match.

The range has been developed through the Bell tradition of listening to our customers. They were looking for a machine that would perform better than conventional haulage solutions in slippery and undulating conditions but didn't need the 'go anywhere' ability of a 6x6 ADT. In response Bell has filled this conspicuous gap in the market with its practical 4x4 alternatives.

Equipped with two-axes, these ADTs are based on the proven articulated technology of their



corresponding 6x6 models. This applies entirely to the powerhead of the vehicles where the proven SSM (sealed switch module), CDU (central display unit) and B-drive automotive controller architecture combine to provide the full array of standard Bell productivity and safety features, including i-Tip, Tipsafe, Hill Assist and onboard weighing with Fleetm@tic® integration. Bell 4x4 ADTs continue to set benchmarks in terms of reliability, efficiency and driving comfort with their practical design.

Delivering productivity during adverse weather conditions where rigid machines are unable to operate, the Bell 4x4 range also tolerates less site maintenance, which has large cost and hassle implications for many sites. In addition, 4x4 trucks are proven to cause less road damage than a 6x6 ADT, where the three-axle configuration tends to scuff the road surface when turning.



- The machine provides superior retardation through all wheels, increasing braking efficiency and reducing wear.

- These features combine to provide superior tyre life compared to similar sized rigid trucks in almost all applications.

- Adaptive front suspension provides superior ride comfort whilst rear suspension on the B45E and B60E improves comfort even further, which ultimately results in higher productivity.

- The flat-bottom bin design reduces carryback, increasing efficiency and reducing contamination in certain applications.

- In deep, soft mud they won't necessarily match their three-axle counterparts, but they have proven themselves to be more than capable machines in challenging conditions.



Specifications	B30E 4x4	B45E 4x4	B60E 4x4
Maximum net power	260 kW (348 hp)	390 kW (523 hp)	430 kW (577 hp)
Operating mass			
Empty	23 626 kg (52 095 lbs)	34 995 kg (77 150 lbs)	45 396 kg (100 081 lbs)
Loaded	51 626 kg (113 835 lbs)	75 995 kg (167 540 lbs)	100 396 kg (221 335 lbs)
Rated payload	28 000 kg (61 729 lbs)	41 000 kg (90 390 lbs)	55 000 kg (121 254 lbs)
2:1 heaped capacity	18,5 m ³ (24 yd ³)	25 m ³ (33 yd ³)	35 m ³ (45,8 yd ³)



- The oscillation joint, inherited from the proven Bell 6x6 range, is what makes an ADT by keeping the wheels on the ground to ensure traction when driving over rough terrain.
- Articulated steering between the front and rear chassis produces much tighter turning circles than most steered axle trucks and make the Bell 4x4 range ideal for tight sites.
- By configuring the driveline to direct drive to all wheels, Bell 4x4 trucks can go places where conventional trucks cannot.



M

The **B30E 4x4** is internationally successful as a most economical solution for bulk handling.



L

The **B45E 4x4** is designed for flexible use in quarrying and smaller mining operations.



XL

The **B60E 4x4** has been uncompromisingly engineered for high productivity in mining under all weather conditions.

Smarter fleet management



Cutting edge technology, helping you run your fleet smarter. Providing accurate, up-to-date operational data, production data and diagnostic data.

The key to a productive and profitable fleet, lies in the ability to monitor and manage your machines and operators efficiently. Machine operational data is processed and compiled into useful production and performance statistics, accessible via the Bell Fleetm@tic® website. These reports are also automated and emailed directly to you. The two monitoring packages that we have available, are:

- **The Classic Package** supplies you with good enough information for you to have a very good understanding of how your machine is operating for each shift that it runs. This package comes standard with the machine for 2 years.
- **The Premium Package** is focused on customers who need to have extremely detailed information of the machine's operation. For this package we offer similar information to that of the Classic Package but for each individual laden - unladen cycle. In addition, live tracking is available on the Fleetm@tic® website on a per minute basis.

Fleetm@tic®:

- Maximise productivity
- Generate machine utilisation reports
- Identify operator training requirements
- Pro-active maintenance planning
- Implement safety features
- Receive machine fault codes as well as suggested trouble shooting procedures
- Protect investments
- Receive real time geospatial data



B30E 4x4 Articulated Dump Truck

ENGINE

Manufacturer
Mercedes Benz

Model
OM936LA

Configuration
Inline 6, turbocharged and intercooled

Maximum Net Power
260 kW (348 hp) at 1 800 rpm in accordance with UN ECE R120

Gross Torque
1 450 Nm (1 069 lbft) @ 1 200 -1 600 rpm

Displacement
7,7 litres (469 cu.in)

Auxiliary Brake
Jacobs Engine Brake®

Fuel Tank Capacity
302 litres (79.78 US gal)

AdBlue® Tank Capacity
31 litres (8.2 US gal)

Certification
OM936LA meets EU Stage V / EPA Tier 4 Final emissions regulations

TRANSMISSION

Manufacturer
Allison

Model
3400 P ORS

Configuration
Fully automatic planetary transmission

Layout
Engine mounted

Gear Layout
Constant meshing planetary gears, clutch operated

Gears
6 Forward, 1 Reverse

Clutch Type
Hydraulically operated multi-disc

Control Type
Electronic

Torque Control
Hydrodynamic with lock-up in all gears

TRANSFER CASE

Manufacturer
Kessler

Series
W1400

Layout
Remote mounted

Gear Layout
Three in-line helical gears

Output Differential
Interaxle 33/67 proportional differential. Automatic inter-axle differential lock.

AXLES

Manufacturer
Bell

Model
Front: Bell 18T
Rear: Bell 36T

Front Differential
High input limited slip differential with spiral bevel gears

Final Drive
Outboard heavy duty planetary on all axles

BRAKING SYSTEM

Service Brake
Dual circuit, full hydraulic actuation wet disc brakes on front and rear axles. Wet brake oil is circulated through a filtration and cooling system.

Maximum brake force:
284 kN (63 859 lbf)

Park & Emergency
Spring applied, air released driveline mounted disc

Maximum brake force:
396 kN (89 000 lbf)

Auxiliary Brake
Jacobs Engine Brake®. Automatic retardation through electronic activation of wet brake system.

Total Retardation Power
Continuous: 332 kW (445 hp)
Maximum: 723 kW (969 hp)

WHEELS

Type
Radial Earthmover

Tyre
Front: 23.5 R 25
Rear: 875/65 R 29

FRONT SUSPENSION

Semi-independent, leading A-frame supported by hydro-pneumatic suspension struts.

Optional active dual springrate Comfort Ride suspension available, including height control.

HYDRAULIC SYSTEM

Full load sensing system serving the prioritized steering, body tipping and brake functions. A ground-driven, load sensing emergency steering pump is integrated into the main system.

Pump Type
Variable displacement load sensing piston

Flow
202 L/min (53 gal/min)

Pressure
310 Bar (4 500 psi)

Filter
5 microns

STEERING SYSTEM

Double acting cylinders, with ground-driven emergency steering pump.

Lock to lock turns
4,1

Steering Angle
45°

DUMPING SYSTEM

Two double-acting, single stage, dump cylinders

Raise Time
12 s

Lowering Time
10 s

Tipping Angle
70° standard, or any lower angle programmable

PNEUMATIC SYSTEM

Air drier with heater and integral unloader valve, serving park brake and auxiliary functions.

System Pressure
8,1 Bar (117 psi)

ELECTRICAL SYSTEM

Voltage
24 V

Battery Type
Two AGM (Absorption Glass Mat) type.

Battery Capacity
2 X 75 Ah

Alternator Rating
28V 100A

VEHICLE SPEEDS

Gear	km/h	mph
1st	8	5
2nd	14	9
3rd	19	12
4th	29	18
5th	42	26
6th	49	30
R	7	4

CAB

ROPS/FOPS certified 74 dBA internal sound pressure measured according to ISO 6396.

Load Capacity & Ground Pressure

OPERATING WEIGHTS*		GROUND PRESSURE		LOAD CAPACITY		OPTION WEIGHTS	
UNLADEN	kg (lb)	LADEN-No Sinkage		BODY	m ³ (yd ³)		
Front	11 499 (25 355)	23.5 R 25	kPa (Psi)	Struck Capacity	15 (19,5)	Bin liner	1 380 (3 042)
Rear	12 127 (26 740)			Front	295 (42,8)	SAE 2:1 Capacity	18,5 (24)
Total	23 626 (52 095)	875/65 R 29	kPa (Psi)	SAE 1:1 Capacity	21,5 (28)		
				Rear	442 (64)	SAE 2:1 Capacity with Tailgate	19,5 (25,5)
						23.5 R25	544 (1 199)
Front	13 951 (30 762)					875/65 R29	1 338 (2 950)
Rear	37 675 (83 073)			Rated Payload	28 000 kg		
Total	51 626 (113 835)				(61 729 lbs)		

* including additional equipment (tailgate)

Dimensions

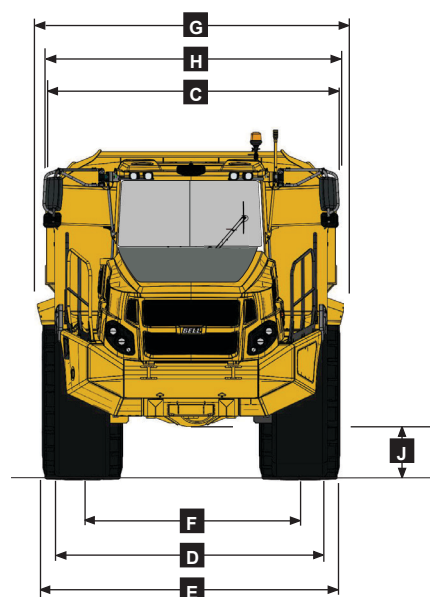
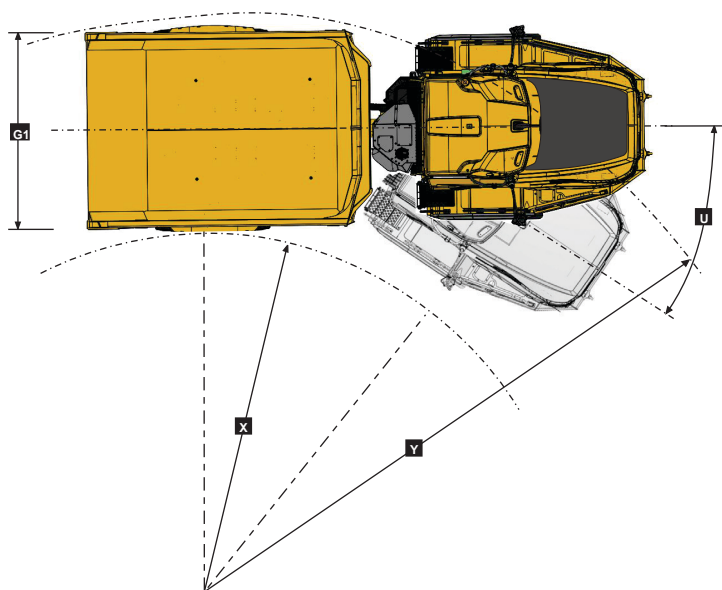
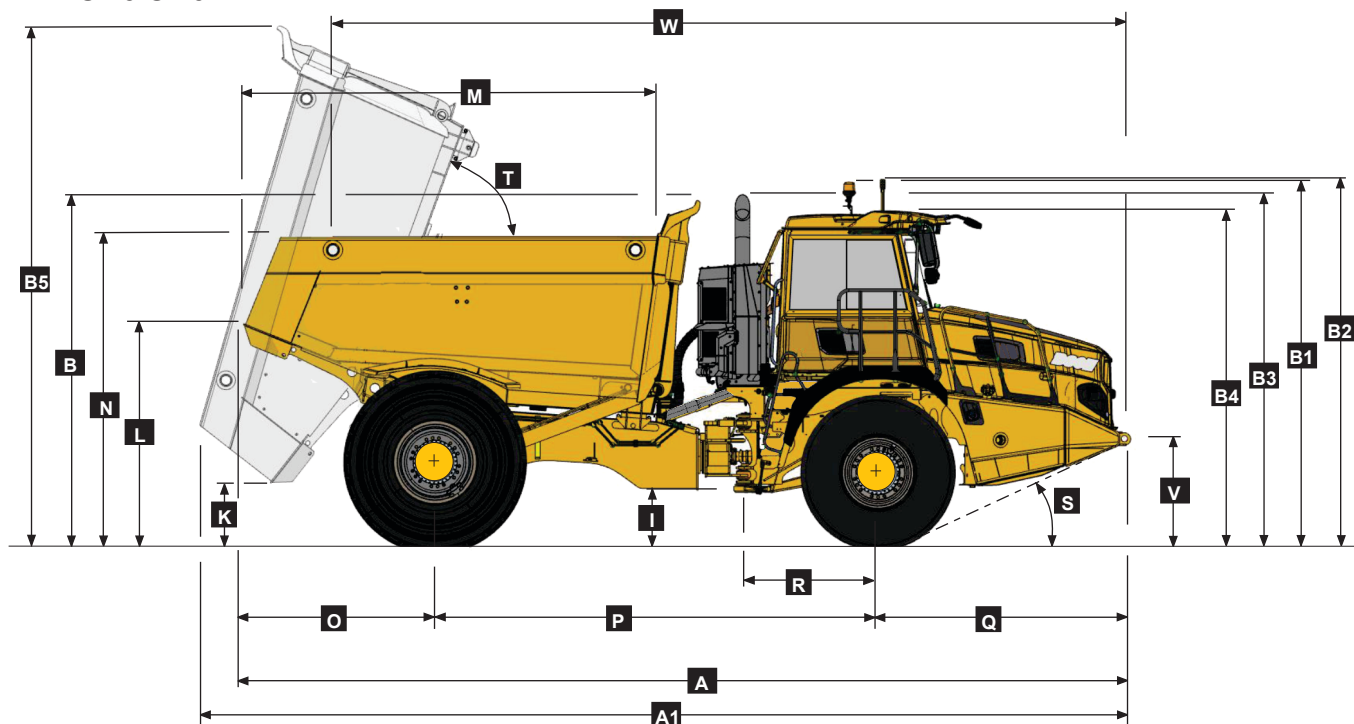

Machine Dimensions

A	Length - Transport Position	9 122 mm	(29.11 ft.)	J	Ground Clearance - Front Axle	480 mm	(18.9 in.)
A1	Length - Bin Fully Tipped	9 709 mm	(31.10 ft.)	K	Ground Clearance - Bin Fully Tipped	444mm	(17.5 in.)
B	Height - Transport Position (no exhaust stack)	3 548 mm	(11.8 ft.)	L	Bin Lip Height - Transport Position	2 331 mm	(7.8 ft.)
B1	Height - Rotating Beacon	3 718 mm	(12.2 ft.)	M	Bin Length	4 271 mm	(14.00 ft.)
B2	Height - Load Light	3 740 mm	(12.3 ft.)	N	Load over Height	3 207 mm	(10.6 ft.)
B3	Height - Exhaust Stack	3 605 mm	(11.10 ft.)	O	Rear Axle Centre to Bin Rear	1 957 mm	(6.5 ft.)
B4	Height - Cab	3 418 mm	(11.3 ft.)	P	Rear Axle Centre to Front Axle Centre	4 560 mm	(14.12 ft.)
B5	Bin Height - Fully Tipped	5 310 mm	(17.5 ft.)	Q	Front Axle Centre to Machine Front	2 605 mm	(8.7 ft.)
C	Width Over Mudguards	2 985 mm	(9.10 ft.)	R	Front Axle Centre to Artic Centre	1 360 mm	(4.6 ft.)
D	Width Over Tyres - Front - 23.5R25	2 998 mm	(9.10 ft.)	S	Approach Angle	25 °	
E	Width Over Tyres - Rear - 875/65 R29	3 270 mm	(10.9 ft.)	T	Maximum Bin Tip Angle	70 °	
F	Tyre Track Width - Front	2 390 mm	(7.10 ft.)	U	Maximum Articulation Angle	45 °	
F	Tyre Track Width - Rear	2 386 mm	(7.10 ft.)	V	Front Tie Down Height	1 040 mm	(3.5 ft.)
G	Width over Bin	3 383 mm	(11.2 ft.)	W	Machine Lifting Centres	8 126 mm	(26.8 ft.)
G1	Width over Tailgate	3 480 mm	(11.5 ft.)	X	Inner Turning Circle Radius	3 488 mm	(11.5 ft.)
H	Width over Mirrors - Operating Position	3 260 mm	(10.9 ft.)	Y	Outer Turning Circle Radius	7 385 mm	(24.3 ft.)
I	Ground Clearance - Artic	539 mm	(21.22 in.)				

B30E 4x4

Gradeability/Rimpull

1. Determine tractive resistance by finding intersection of vehicle mass line and grade line. NOTE: 2% typical rolling resistance is already assumed in chart and grade line.
2. From this intersection, move straight right across charts until line intersects rimpull curve.
3. Read down from this point to determine maximum speed attained at that tractive resistance.

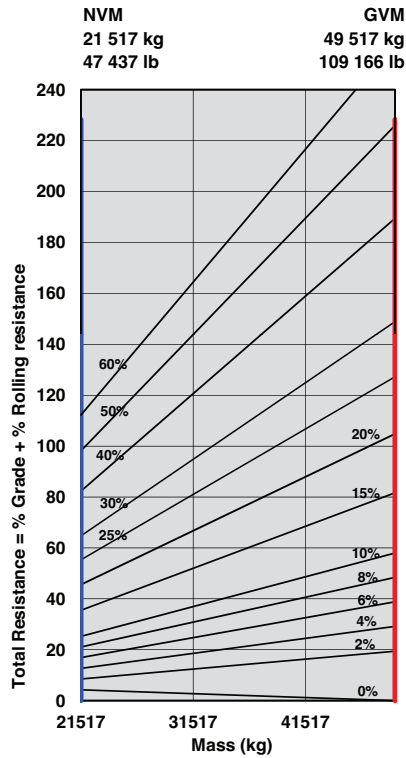

ADT, B30E 4x4 Tractive Effort

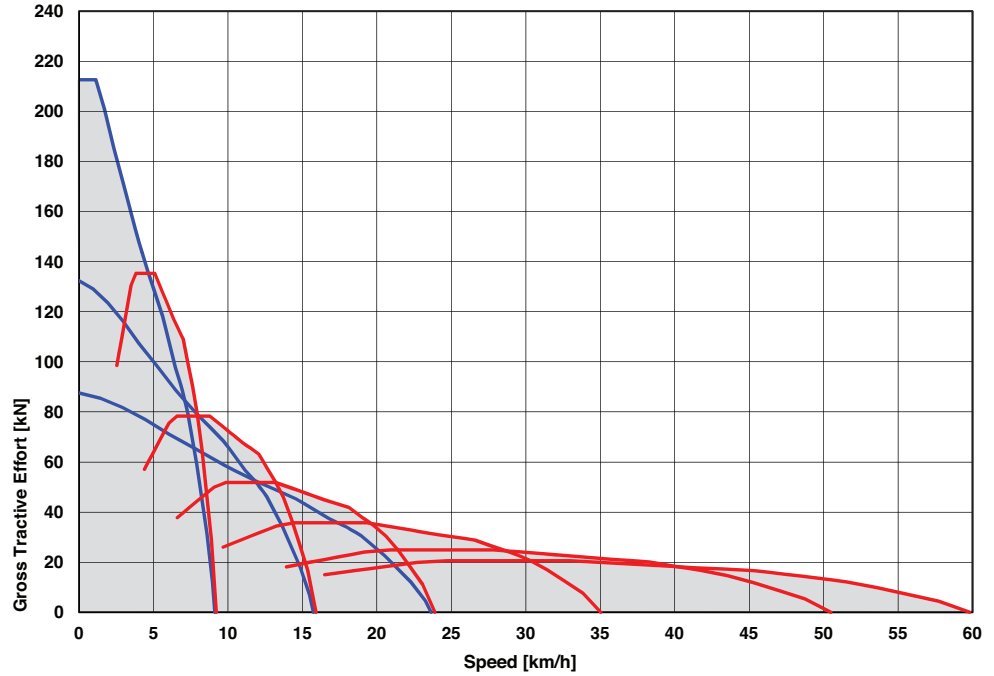

Retardation

1. Determine retardation force required by finding intersection of vehicle mass line.
2. From this intersection, move straight right across charts until line intersects the curve. NOTE: 2% typical rolling resistance is already assumed in chart.
3. Read down from this point to determine maximum speed.

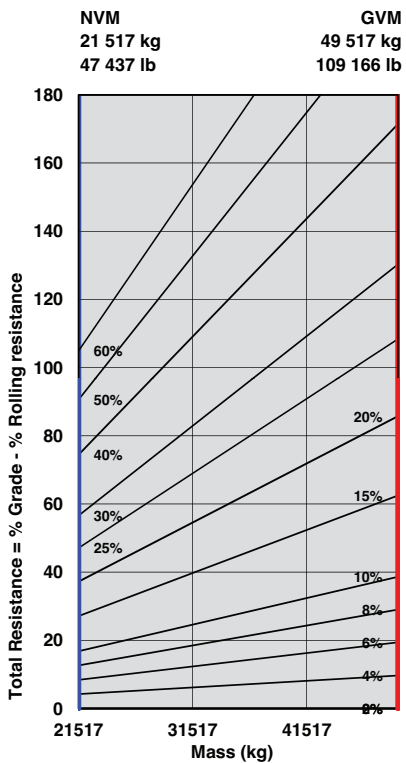

ADT, B30E 4x4 Retardation

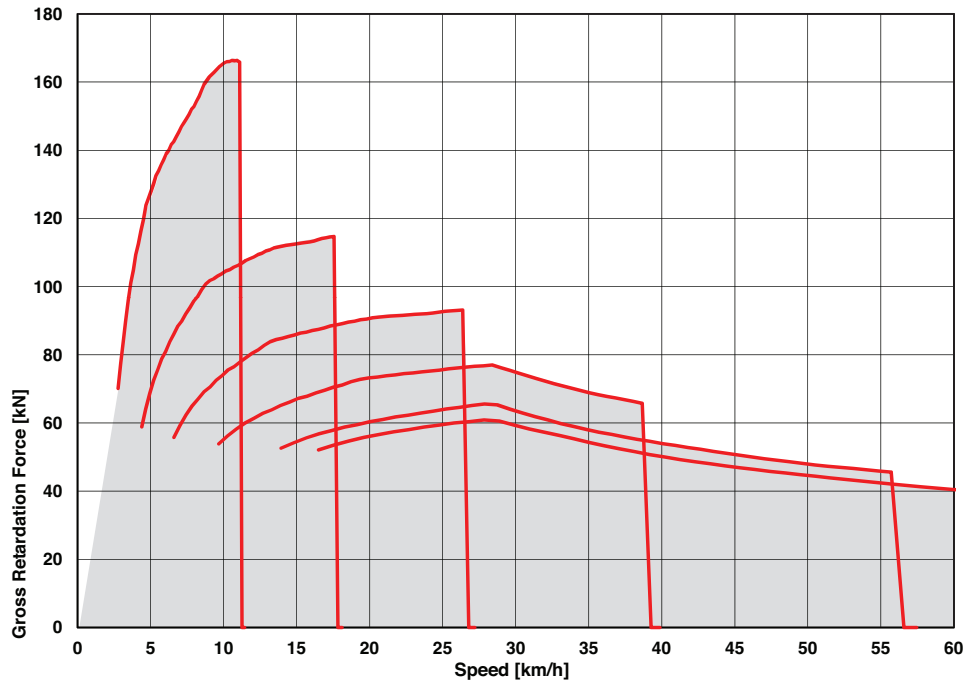

B45E 4x4 Articulated Dump Truck

ENGINE

Manufacturer
Mercedes Benz (MTU)

Model
OM471LA (MTU 6R 1300)

Configuration
Inline 6, turbocharged and intercooled

Maximum Net Power
390 kW (523 hp) at 1 600 rpm in accordance with UN ECE R120

Gross Torque
2 600 Nm (1 917 lbf) @ 1 300 rpm

Displacement
12,8 litres (781 cu.in)

Auxiliary Brake
Jacobs Engine Brake®

Fuel Tank Capacity
352 litres (93 US gal)

AdBlue® Tank Capacity
40 litres (11 US gal)

Certification
OM471LA (MTU 6R 1300) meets EU Stage V / EPA Tier 4 Final emissions regulations.

TRANSMISSION

Manufacturer
Allison

Model
4700 ORS

Configuration
Fully automatic planetary transmission

Layout
Engine mounted

Gear Layout
Constant meshing planetary gears, clutch operated

Gears
7 Forward, 1 Reverse

Clutch Type
Hydraulically operated multi-disc

Control Type
Electronic

Torque Control
Hydrodynamic with lock-up in all gears

TRANSFER CASE

Manufacturer
Kessler

Series
W2400

Layout
Remote mounted

Gear Layout
Three in-line helical gears

Output Differential
Interaxle 29/71 proportional differential. Automatic inter-axle differential lock.

AXLES

Manufacturer
Bell

Model
Front: Bell 30T
Rear: Kessler D106

Differential
Front: High input controlled traction Differential with spiral bevel gears.

Rear: High input limited slip differential with spiral bevel gears. Traction control functionality provided through speed sensors and brake activation.

Final Drive
Outboard heavy duty planetary on all axles

BRAKING SYSTEM

Service Brake
Dual circuit, full hydraulic actuation wet disc brakes on front and rear axles. Wet brake oil is circulated through a filtration and cooling system.

Maximum brake force: 352 kN (79 132 lbf)

Park & Emergency
Spring applied, air released driveline mounted disc

Maximum brake force: 426 kN (95 768 lbf)

Auxiliary Brake
Jacobs Engine Brake®. Automatic retardation through electronic activation of wet brake system.

Total Retardation Power
Continuous: 442 kW (593 hp)
Maximum: 854 kW (1 145 hp)

WHEELS

Type
Radial Earthmover

Tyre
Front: 775/65 R 29 (26.5 R 25 optional)
Rear: 21.00 R 35 Dual

FRONT SUSPENSION

Semi-independent, leading A-frame supported by hydropneumatic suspension struts.

Optional active dual springrate Comfort Ride suspension available, including height control.

REAR SUSPENSION

Trailing arm cradle supported by hydro-pneumatic suspension struts, with an additional lateral stabiliser.

HYDRAULIC SYSTEM

Full load sensing system serving the prioritized steering, body tipping and brake functions. A ground-driven, load sensing emergency steering pump is integrated into the main system.

Pump Type
Variable displacement load sensing piston

Flow
300 L/min (79 gal/min)

Pressure
280 Bar (4 060 psi)

Filter
5 microns

STEERING SYSTEM

Double acting cylinders, with ground-driven emergency steering pump.

Lock to lock turns
5,5

Steering Angle
42°

DUMPING SYSTEM

Two double-acting, two stage telescopic, dump cylinders

Raise Time
18 s

Lowering Time
16,5 s

Tipping Angle
55° standard, or any lower angle programmable

PNEUMATIC SYSTEM

Air drier with heater and integral unloader valve, serving park brake and auxiliary functions.

System Pressure
8,1 Bar (117 psi)

ELECTRICAL SYSTEM

Voltage
24 V

Battery Type
Two AGM (Absorption Glass Mat) type

Battery Capacity
2 X 75 Ah

Alternator Rating
28V 100A

VEHICLE SPEEDS

1st	3,5 km/h	2,1 mph
2nd	8 km/h	5 mph
3rd	15 km/h	9 mph
4th	21 km/h	13 mph
5th	31 km/h	19 mph
6th	42 km/h	26 mph
7th	48 km/h	30 mph
R	6 km/h	3,7 mph

CAB

ROPS/FOPS certified 77 dBA internal sound pressure measured according to ISO 6396.

Load Capacity & Ground Pressure

OPERATING WEIGHTS*		GROUND PRESSURE		LOAD CAPACITY		OPTION WEIGHTS	
UNLADEN	kg (lb)	LADEN		BODY	m ³ (yd ³)	kg (lb)	
Front	17 584 (38 766)	No Sinkage/Total Contact Area		Struck Capacity	19,5 (25,5)	Bin liner	1 022 (2 253)
Rear	17 411 (38 385)	775/65 R29	kPa (Psi)	SAE 2:1 Capacity	25 (33)	Tailgate	1 373 (3 026)
Total	34 995 (77 150)	Front	297 (43,1)	SAE 1:1 Capacity	29,5 (38)		
				SAE 2:1 Capacity		EXTRA WHEELSET	
LADEN		21.00 R35	kPa (Psi)	with Tailgate	26 (34)	775/65 R29	888 (1 958)
Front	23 143 (51 022)	Rear	405 (58,7)			21.00 R35	1 012 (2 231)
Rear	52 852 (116 518)			Rated Payload	41 000 kg		
Total	75 995 (167 540)				(90 390 lbs)		

* including additional equipment (tailgate)

B45E 4x4

Dimensions

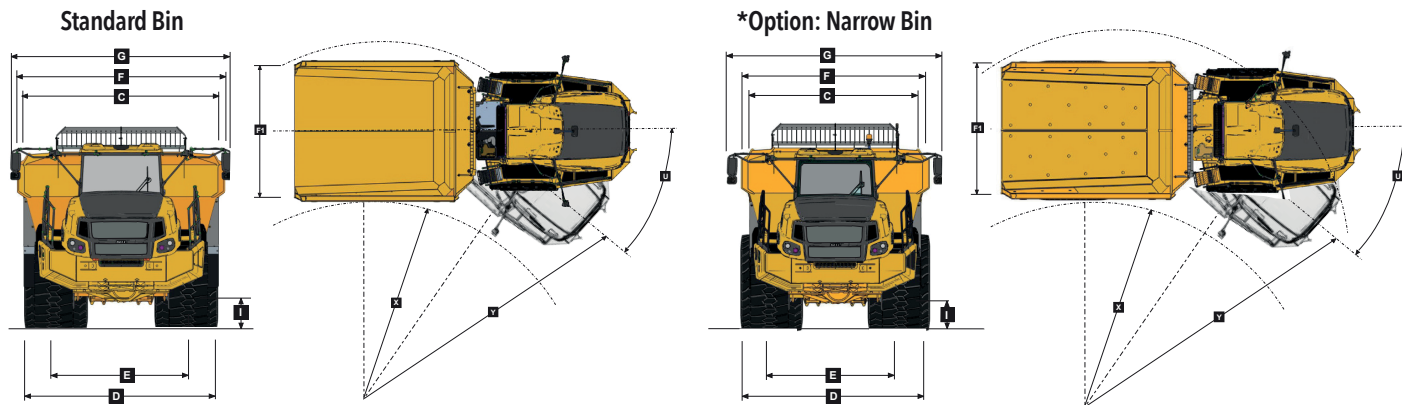
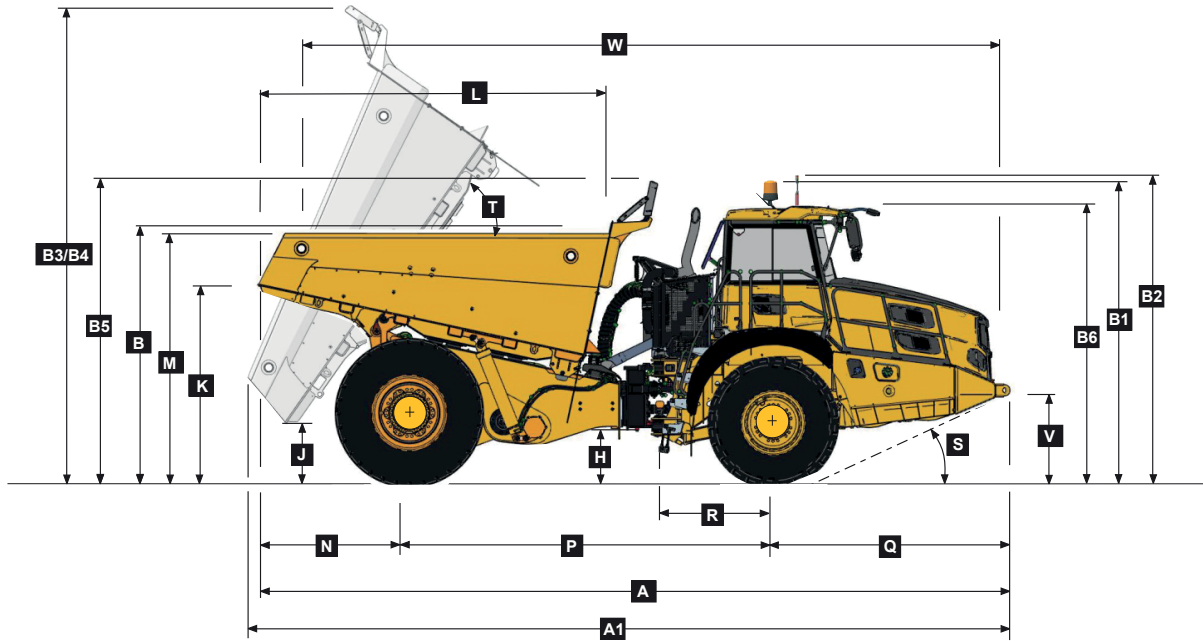

Machine Dimensions

A	Length - Transport Position with Tailgate	10 405 mm (34 ft. 13 in.)	F	Width over Bin	4 265 mm (13 ft. 99 in.)
A*	Option	10 352 mm (33 ft. 96 in.)	F*	Option	3 960 mm (12 ft. 99 in.)
A	Length - Transport Position w/o Tailgate	10 339 mm (33 ft. 11 in.)	F1	Width over Tailgate	4 639 mm (15 ft. 21 in.)
A*	Option	10 336 mm (33 ft. 91 in.)	F1*	Option	4 275 mm (14 ft. 03 in.)
A1	Length - Bin Fully Tipped	10 427 mm (34 ft. 20 in.)	G	Width over Mirrors - Operating Position	4 545 mm (14 ft. 91 in.)
A1*	Option	10 576 mm (34 ft. 70 in.)	H	Ground Clearance - Artic	545 mm (21.46 in.)
B	Height - Transport Position w/o Rock Guard	3 703 mm (12 ft. 14 in.)	I	Ground Clearance - Front Axle	543 mm (21.34 in.)
B*	Option	3 874 mm (12 ft. 71 in.)	J	Ground Clearance - Bin Fully Tipped	890 mm (2 ft. 11 in.)
B	Height - Transport Position with Rock Guard	4 176 mm (13 ft. 70 in.)	K	Bin Lip Height - Transport Position	2 630 mm (8 ft. 62 in.)
B*	Option	4 374 mm (14 ft. 35 in.)	K*	Option	2 618 mm (8 ft. 59 in.)
B1	Height - Rotating Beacon	4 038 mm (13 ft. 3 in.)	L	Bin Length	4 833 mm (15 ft. 10 in.)
B2	Height - Load Light	4 127 mm (13 ft. 6 in.)	L*	Option	4 913 mm (16 ft. 12 in.)
B3	Bin Height - Fully Tipped w/o Rock Guard	6 228 mm (20 ft. 43 in.)	M	Load over Height	3 485 mm (11 ft. 43 in.)
B3*	Option	6 327 mm (20 ft. 7.76 in.)	M*	Option	3 671 mm (12 ft. 04 in.)
B4	Bin Height - Fully Tipped with Rock Guard	6 485 mm (21 ft. 27 in.)	N	Rear Axle Centre to Bin Rear	2 084 mm (6 ft. 10 in.)
B4*	Option	6 585 mm (21 ft. 60 in.)	P	Rear Axle Centre to Front Axle Centre	5 000 mm (16.4 ft.)
B5	Height - Rock Guard Operating Position	4 206 mm (13 ft. 79 in.)	Q	Front Axle Centre to Machine Front	3 256 mm (10 ft. 8 in.)
B5*	Option	4 374 mm (14 ft. 35 in.)	R	Front Axle Centre to Artic Centre	1 558 mm (5 ft. 1 in.)
B6	Height - Cab	3 802 mm (12 ft. 47 in.)	S	Approach Angle	24°
C	Width over Mudguards	4 000 mm (13 ft. 12 in.)	T	Maximum Bin Tip Angle	55°
C*	Option	3 603 mm (11 ft. 82 in.)	U	Maximum Articulation Angle	42°
D	Width over Front Tyres 775/65R29	3 556 mm (11 ft. 8 in.)	V	Front Tie Down Height	1 262 mm (4 ft. 2 in.)
D1	Width over Front Tyres 26.5R25	3 425 mm (11.2 ft.)	W	Machine Lifting Centres	9 673 mm (31 ft. 73 in.)
D	Width over Rear Tyres 21.00R35	3 960 mm (13 ft.)	W*	Option	9 697 mm (31 ft. 81 in.)
E	Tyre Track Width Front 775/65R29	2 905 mm (9.5 ft.)	X	Inner Turning Circle Radius	3 956 mm (12.9 ft.)
E1	Tyre Track Width Front 26.5R25	2 793 mm (9.2 ft.)	Y	Outer Turning Circle Radius	8 655 mm (28.4 ft.)
E	Tyre Track Width Rear 21.00R35	2 677 mm (8.8 ft.)			

Gradeability/Rimpull

1. Determine tractive resistance by finding intersection of vehicle mass line and grade line. NOTE: 2% typical rolling resistance is already assumed in chart and grade line.
2. From this intersection, move straight right across charts until line intersects rimpull curve.
3. Read down from this point to determine maximum speed attained at that tractive resistance.

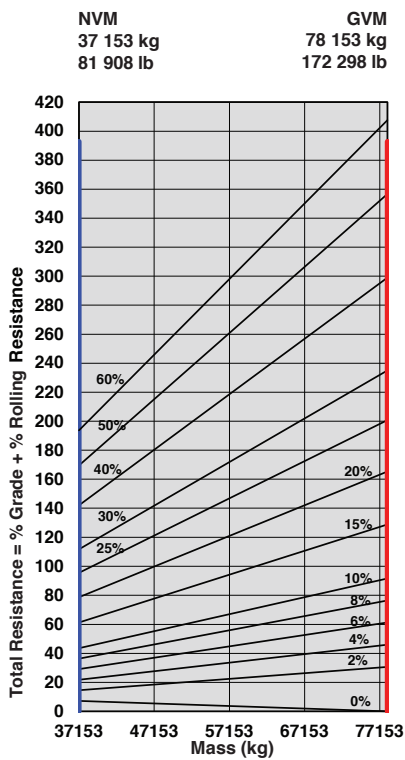

ADT, B45E 4X4 - Tractive Effort

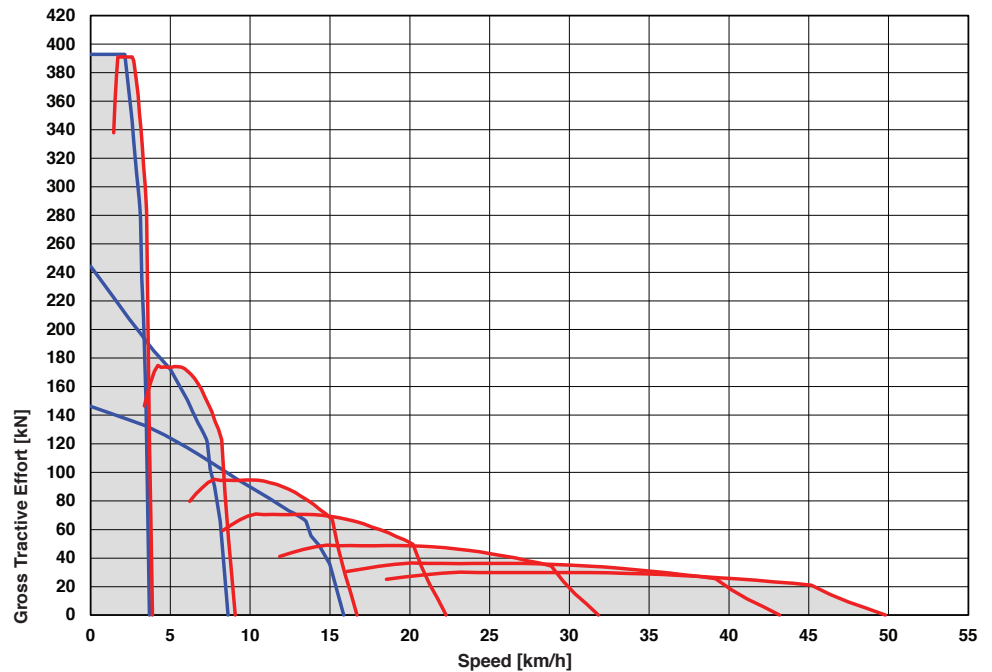

Retardation

1. Determine retardation force required by finding intersection of vehicle mass line.
2. From this intersection, move straight right across charts until line intersects the curve. NOTE: 2% typical rolling resistance is already assumed in chart.
3. Read down from this point to determine maximum speed.

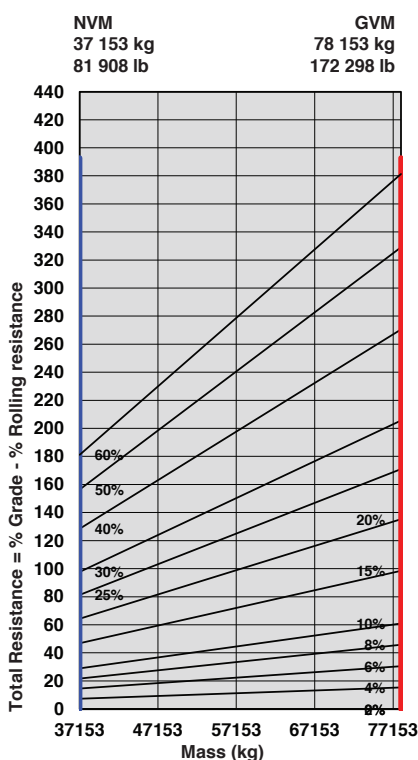

ADT, B45E 4x4 - Retardation

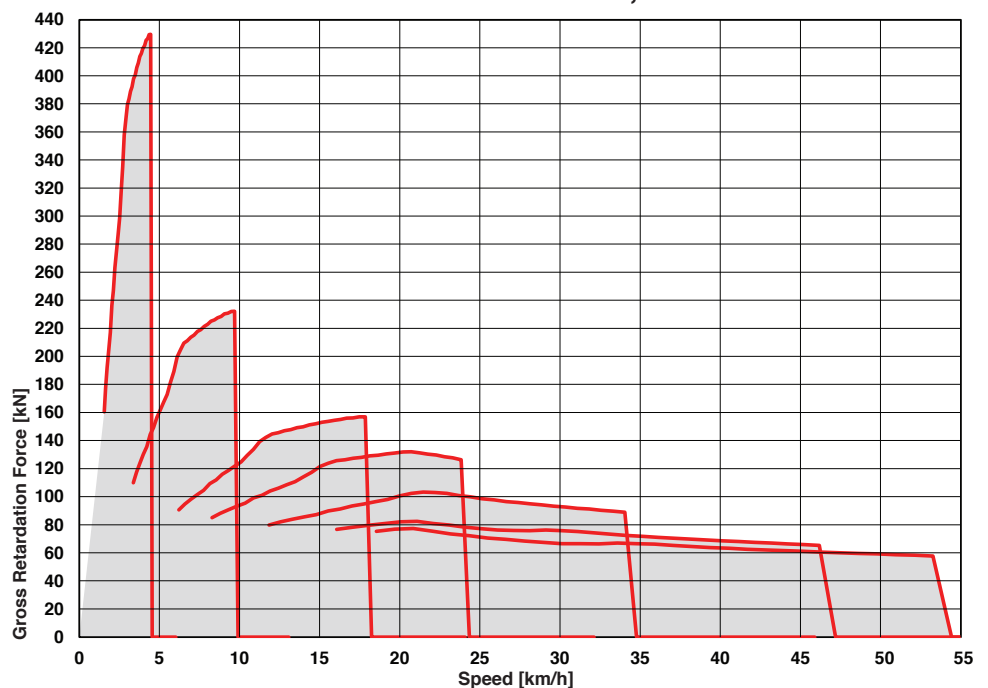

B60E 4x4 Articulated Dump Truck

ENGINE

Manufacturer
Mercedes Benz (MTU)

Model
OM473LA (MTU 6R 1500)

Configuration
Inline 6, turbocharged and intercooled

Maximum Net Power
430 kW (577 hp) at 1 600 rpm in accordance with UN ECE R120

Gross Torque
2 850 Nm (2 102 lbft) @ 1 300 rpm

Displacement
15,6 litres (952 cu.in)

Auxiliary Brake
Jacobs Engine Brake®

Fuel Tank Capacity
494 litres (130 US gal)

AdBlue® Tank Capacity
40 litres (11 US gal)

Certification
OM473LA (MTU 6R 1500) meets EU Stage V / EPA Tier 4 Final emissions regulations.

TRANSMISSION

Manufacturer
Allison

Model
4800 ORS

Configuration
Fully automatic planetary transmission

Layout
Engine mounted

Gear Layout
Constant meshing planetary gears, clutch operated

Gears
7 Forward, 1 Reverse

Clutch Type
Hydraulically operated multi-disc

Control Type
Electronic

Torque Control
Hydrodynamic with lock-up in all gears

TRANSFER CASE

Manufacturer
Kessler

Series
W2400

Layout
Remote mounted

Gear Layout
Three in-line helical gears

Output Differential
Interaxle 29/71 proportional differential. Automatic inter-axle differential lock.

AXLES

Manufacturer
Front: Bell
Rear: Kessler

Model
Front: 30T
Rear: 71T

Differential
Front: High input controlled traction differential with spiral bevel gears.

Rear: High input limited slip differential with spiral bevel gears. Traction control functionality provided through speed sensors and brake activation.

Final Drive
Outboard heavy duty planetary on all axles

BRAKING SYSTEM

Service Brake
Dual circuit, full hydraulic actuation wet disc brakes on front and rear axles. Wet brake oil is circulated through a filtration and cooling system.

Maximum brake force:
446 kN (100 264 lbf)

Park & Emergency
Spring applied, air released driveline mounted disc

Maximum brake force:
341 kN (76 659 lbf)

Auxiliary Brake
Jacobs Engine Brake®.
Automatic retardation through electronic activation of wet brake system.

Total Retardation Power
Continuous: 574 kW (770 hp)
Maximum: 983 kW (1 318 hp)

WHEELS

Type
Radial Earthmover

Tyre
Front: 875/65 R 29
Rear: 24.00 R 35 Dual

FRONT SUSPENSION

Semi-independent, leading A-frame supported by hydro-pneumatic suspension struts. Active dual springrate Comfort Ride suspension, including height control.

REAR SUSPENSION

Trailing arm cradle supported by hydro-pneumatic suspension struts, with an additional lateral stabiliser.

HYDRAULIC SYSTEM

Full load sensing system serving the prioritized steering, body tipping, suspension and brake functions. A ground-driven, load sensing emergency steering pump is integrated into the main system.

Pump Type
Variable displacement load sensing piston

Flow
330 L/min (87 gal/min)

Pressure
280 Bar (4 060 psi)

Filter
5 microns

STEERING SYSTEM

Double acting cylinders, with ground-driven emergency steering pump.

Lock to lock turns
5,5

Steering Angle
42°

DUMPING SYSTEM

Two double-acting, two stage telescopic, dump cylinders

Raise Time
18 s

Lowering Time
16,5 s

Tipping Angle
55° standard, or any lower angle programmable

PNEUMATIC SYSTEM

Air drier with heater and integral unloader valve, serving park brake and auxiliary functions.

System Pressure
8,1 Bar (117 psi)

ELECTRICAL SYSTEM

Voltage
24 V

Battery Type
Two AGM (Absorption Glass Mat) type

Battery Capacity
2 X 75 Ah

Alternator Rating
28V 100A

MAX. VEHICLE SPEED

1st	4 km/h	2,5 mph
2nd	8 km/h	5,6 mph
3rd	16 km/h	10,6 mph
4th	21 km/h	13,7 mph
5th	30 km/h	20 mph
6th	41 km/h	27 mph
7th	47 km/h	32 mph
R	6 km/h	4 mph

CAB

ROPS/FOPS certified 77 dBA internal sound pressure measured according to ISO 6396.

Load Capacity & Ground Pressure

OPERATING WEIGHTS*		GROUND PRESSURE		LOAD CAPACITY		OPTION WEIGHTS	
UNLADEN	kg (lb)	LADEN		BODY	m ³ (yd ³)	kg (lb)	
Front	20 151 (44 425)	(No sinkage/		Struck Capacity	27 (35,3)	Bin liner	1 117 (2 463)
Rear	25 245 (55 656)	Total Contact Area Method)		SAE 2:1 Capacity	35 (45,8)	Tailgate	1 512 (3 333)
Total	45 396 (100 081)	875/65 R29	kPa (Psi)	SAE 1:1 Capacity	42 (54,9)		
		Front	333 (48,2)	SAE 2:1 Capacity	36 (47,1)	EXTRA WHEELSET	
				with Tailgate		875/65 R29	1 338 (2 950)
						24.00 R35	1 240 (2 734)
LADEN			kPa	Rated Payload	55 000 kg		
Front	26 751 (58 976)	24.00 R35			(121 254 lb)		
Rear	73 645 (162 359)	Rear	478 (69,3)				
Total	100 396 (221 335)						

* including additional equipment (tailgate)

Dimensions

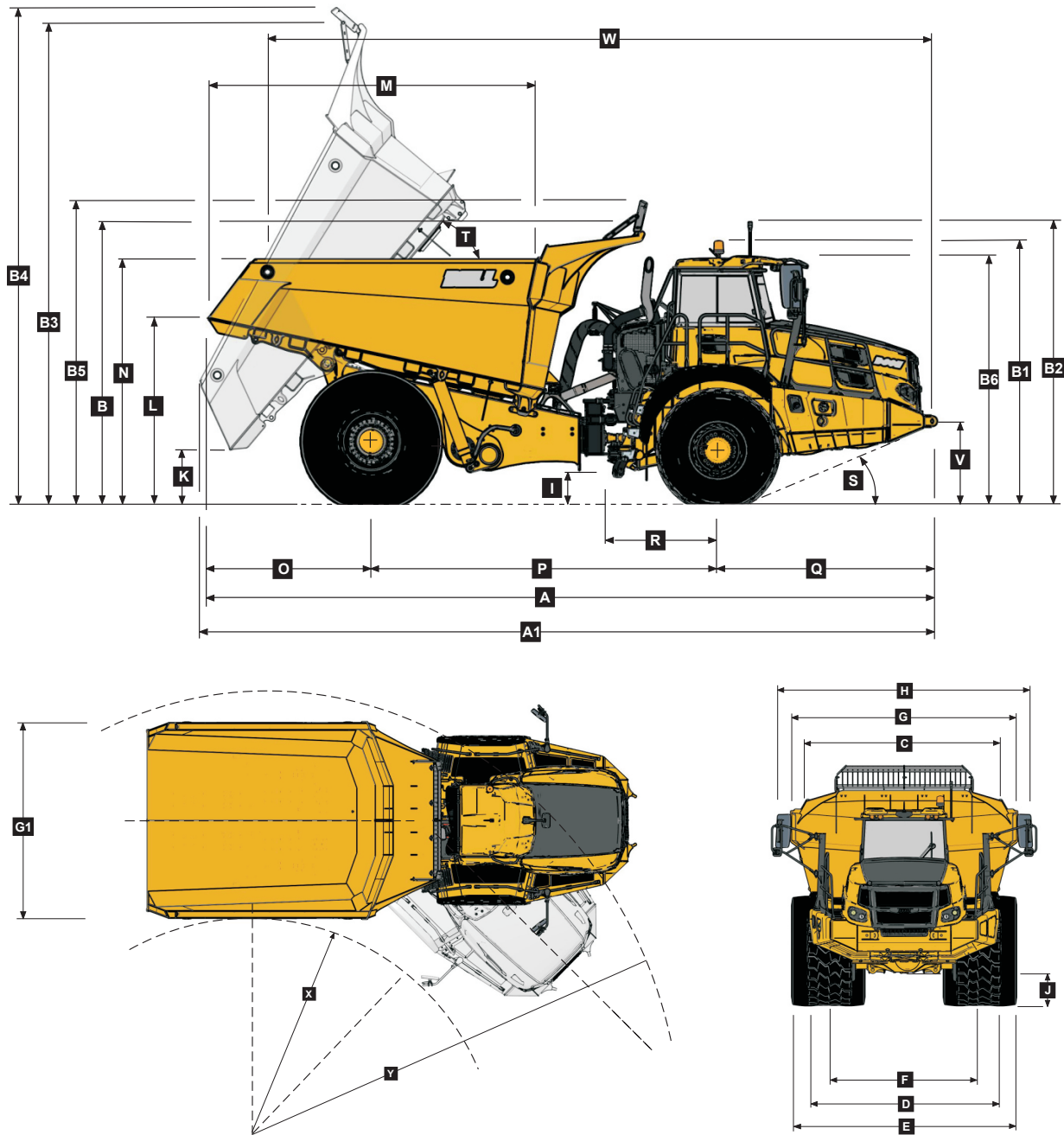

Machine Dimensions

A	Length - Transport Position	11 114 mm	(33.23 ft.)	I	Ground Clearance - Artic	561 mm	(22.09 in.)
A1	Length - Bin Fully Tipped	11 178 mm	(36 ft. 8 in.)	J	Ground Clearance - Front Axle	554 mm	(21.81 in.)
B	Height - Transport Position w/o Rock Guard	4 209 mm	(13 ft.10 in.)	K	Ground Clearance - Bin Fully Tipped	851 mm	(33.5 in.)
B	Height - Transport Position with Rock Guard	4 212 mm	(13 ft.10 in.)	L	Bin Lip Height - Transport Position	2 952 mm	(9 ft. 8 in.)
B1	Height - Rotating Beacon	4 050 mm	(13 ft. 3 in.)	M	Bin Length	5 036 mm	(16 ft. 6 in.)
B2	Height - Load Light	4 333 mm	(14 ft. 2 in.)	N	Load over Height	3 824 mm	(12 ft. 7 in.)
B3	Bin Height - Fully Tipped w/o Rock Guard	7 476 mm	(24 ft. 6 in.)	O	Rear Axle Centre to Bin Rear	2 477 mm	(8 ft. 2 in.)
B4	Bin Height - Fully Tipped with Rock Guard	7 692 mm	(25 ft. 3 in.)	P	Rear Axle Centre to Front Axle Centre	5 285 mm	(17 ft. 4 in.)
B5	Height - Rock Guard Operating Position	4 675 mm	(15 ft. 4 in.)	Q	Front Axle Centre to Machine Front	3 352 mm	(11 ft.)
B6	Height - Cab	3 813 mm	(12 ft. 6 in.)	R	Front Axle Centre to Artic Centre	1 558 mm	(5 ft. 1 in.)
C	Width over Mudguards	3 790 mm	(12 ft. 5 in.)	S	Approach Angle	22°	
D	Width over Front Tyres 875/65 R29	3 832 mm	(12 ft. 7 in.)	T	Maximum Bin Tip Angle	55°	
E	Width over Rear Tyres 24.00R35	4 444 mm	(14 ft. 7 in.)	U	Maximum Articulation Angle	42°	
F	Tyre Track Width Front 875/65R29	2 949 mm	(9 ft. 8 in.)	V	Front Tie Down Height	1 263 mm	(4 ft. 2 in.)
F	Tyre Track Width Rear 24.00R35	2 992 mm	(9 ft. 10 in.)	W	Machine Lifting Centres	10 116 mm	(33 ft. 2 in.)
G	Width over Bin	4 487 mm	(14 ft. 9 in.)	X	Inner Turning Circle Radius	4 246 mm	(13 ft. 11 in.)
G1	Width over Tailgate	4 800 mm	(15 ft. 9 in.)	Y	Outer Turning Circle Radius	9 216 mm	(30 ft. 3 in.)
H	Width over Mirrors - Operating Position	5 242 mm	(17 ft. 2 in.)				

B60E 4x4

Gradeability/Rimpull

1. Determine tractive resistance by finding intersection of vehicle mass line and grade line. NOTE: 2% typical rolling resistance is already assumed in chart and grade line.
2. From this intersection, move straight right across charts until line intersects rimpull curve.
3. Read down from this point to determine maximum speed attained at that tractive resistance.

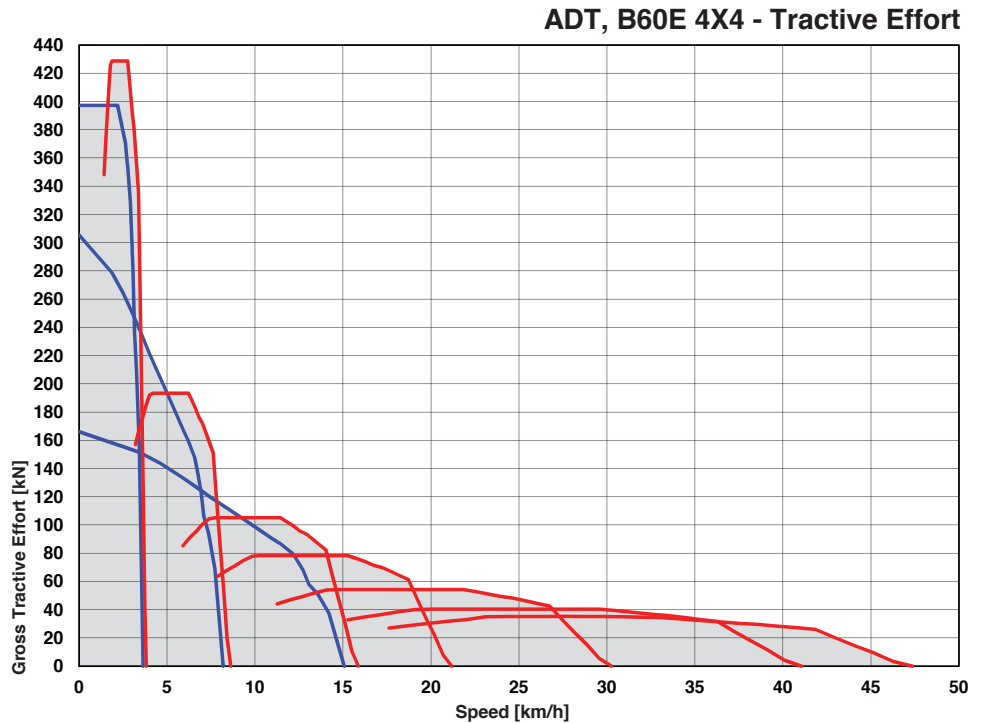
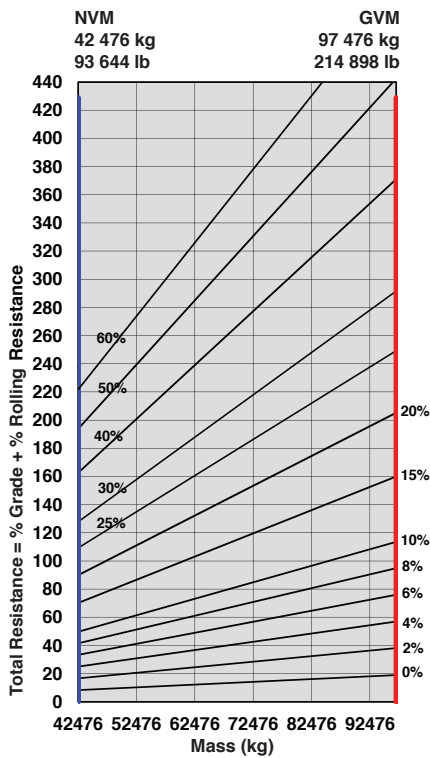

Retardation

1. Determine retardation force required by finding intersection of vehicle mass line.
2. From this intersection, move straight right across charts until line intersects the curve. NOTE: 2% typical rolling resistance is already assumed in chart.
3. Read down from this point to determine maximum speed.

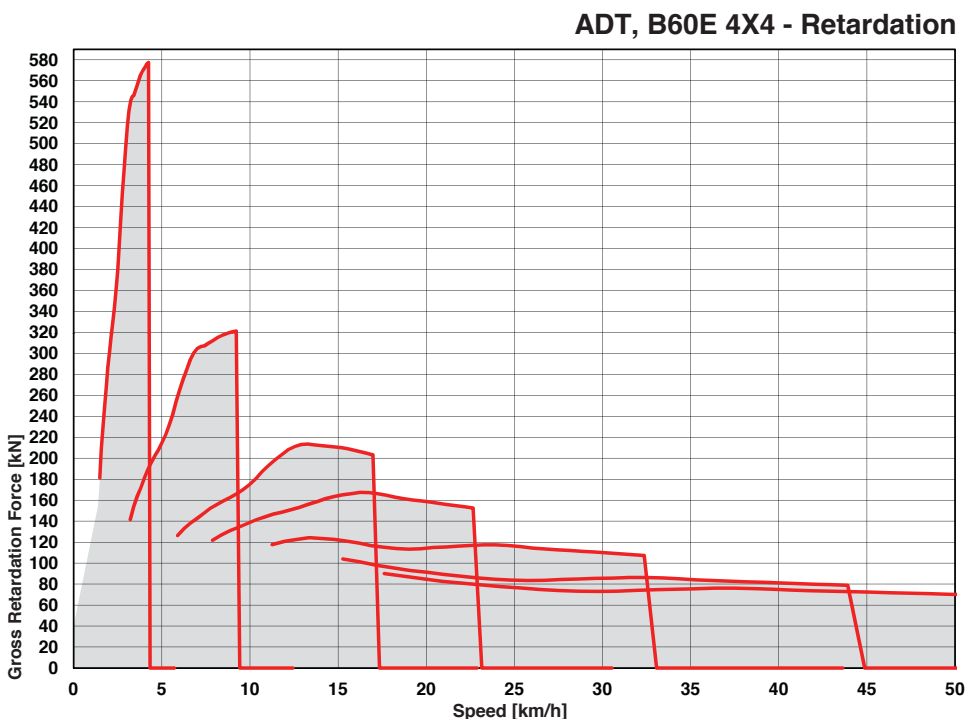
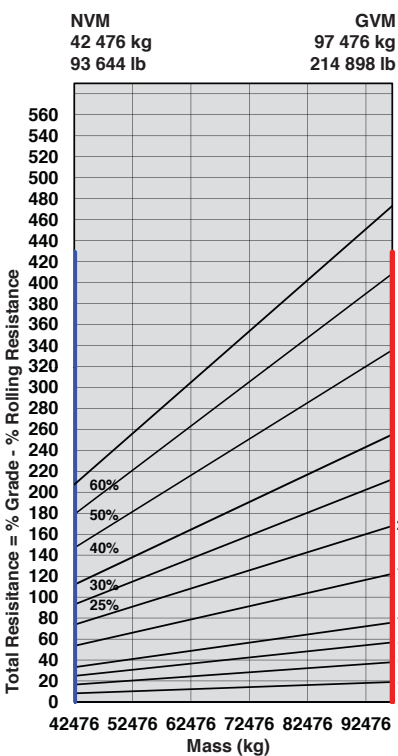

B30E 4x4	B45E 4x4	B60E 4x4	
ENGINE			
□	□	□	Jacobs Engine Brake®
□	□	□	Dual element air cleaner with dust ejector valve
□	□	□	Pre-cleaner with automatic dust scavenging
□	□	□	Water separator
□	□	□	Serpentine drive belt with automatic tensioner
□	□	□	Provision for fast fill
	□	□	Wet-sleeve cylinder liners
COOLING			
□	□	□	Crankshaft mounted electronically controlled viscous fan drive
□	□	□	Fan guard
PNEUMATIC SYSTEM			
□	□	□	Engine-mounted compressor
□	□	□	Air drier with heater
□	□	□	Integral unloader valve
ELECTRICAL SYSTEM			
□	□	□	Battery disconnect
□	□	□	Halogen drive lights
	□	□	LED drive lights
□	□	□	Air horn
□	□	□	Reverse alarm
□	□	□	White noise reverse alarm
□	□	□	Rotating beacon
□	□	□	Pitch roll sensor
□	□	□	LED Artic reverse light
□	□	□	Halogen artic reverse lights
□	□	□	LED reverse lights
STEERING SYSTEM			
□	□	□	Bi-directional ground-driven secondary steering pump
CAB			
□	□	□	ROPS/FOPS certification
□	□	□	Tilt cab
□	□	□	Gas strut-supported door
□	□	□	I-Tip programmable dump-body tip settings
□	□	□	HVAC Climate control system
□	□	□	AM/FM radio with Aux + USB
□	□	□	Rear window guard
□	□	□	Wiper/washer with intermittent control
□	□	□	Tilt and telescoping steering wheel
□	□	□	Center-mount air-suspension seat
□	□	□	Halogen work lights
□	□	□	LED work lights
□	□	□	Rotating beacon: seat belt installation
□	□	□	Remote engine and machine isolation
□	□	□	Remote battery jump start
□	□	□	Retractable 3 point seat belt
□	□	□	Heated seat
□	□	□	Foldaway trainer seat with retractable seat belt
□	□	□	12-volt power outlet
□	□	□	Cab utility bin (removable)
□	□	□	Cup holder
□	□	□	Cooled/heated lunch box
	□	□	Heated mirrors

B30E 4x4	B45E 4x4	B60E 4x4	
CAB (continued)			
□	□		Electric adjustable and heated mirrors
□	□	□	Deluxe 10" color LCD: Speedometer / Fuel gauge / Transmission oil temperature gauge / Engine coolant temperature gauge / LED function/warning indicators and audible alarm / Transmission gear selection / Tachometer / Battery voltage / Hour meter / Odometer / Fuel consumption / Tip counter / Trip timer / Trip distance / Metric/English units / Service codes/diagnostics
□	□	□	Backlit sealed switch module functions with: Wiper control / Lights / Heated mirrors / Retarding aggressiveness / Transfer case differential lock / Transmission gear hold / Dump-body tip limit / Automatic dump-body tip settings / Air conditioner/ Heater controls / Preselected Speed Control
DUMP BODY			
□	□	□	Dump body mechanical lock
□	□	□	Partial body liner
□	□	□	Tailgate
□	□	□	Body heater
□	□	□	Less dump body and cylinders
□	□	□	Bin pole lockout
	□	□	Narrow bin body
	□	□	Rear wheel mudguards
OTHER			
□	□	□	Automatic Traction Control (ATC)
□	□	□	Wet disc brakes
□			23.5 R25 Radial Earthmover tyres (Front)
	□		775/65 R29 Radial Earthmover tyres (Front)
		□	875/65 R29 Radial Earthmover tyres (Front)
	□		26.5 R25 Radial Earthmover tyres (Front-optional)
□			875/65 R29 Radial Earthmover tyres (Rear)
	□		21.00 R35 Dual (Rear)
		□	24.00 R35 Dual (Rear)
□	□		Remote grease banks
□	□	□	Automatic greasing
□	□	□	Onboard Weighing
□	□	□	Load lights: stack
□	□	□	Comfort ride suspension (Front)
	□	□	Comfort ride suspension (Rear)
□	□	□	Reverse camera
□	□	□	Hand rails
□	□	□	Cab peak
□	□	□	High pressure hydraulic filter
□	□	□	Fuel heater
□	□	□	Belly cover
□	□	□	Cross member cover
□	□	□	Remote transmission filters
□	□	□	Engine and transmission remote drain-gravity
□	□	□	Engine and transmission remote drain-scavenge
□	□	□	Window smash button
□	□	□	High visibility mirrors
□	□	□	Fleetm@tic® Classic Package for 2 years
□	□	□	Electronic bonnet opening



All dimensions are shown in millimeters, unless otherwise stated between brackets. Under our policy of continuous improvement, we reserve the right to change technical data and design without prior notice. Photographs featured in this brochure may include optional equipment. Blu@dvantage™ is a trademark of Bell Equipment Co. (PTY) Ltd. AdBlue® is a registered trademark of VDA.

BELL INTERNATIONAL: Tel: +27 (0)35-907 9431

E-mail: marketing@bellequipment.com • www.bellequipment.com

 Tel: +61 (0)8-9355-2442

 Tel: +27 (0)11-928-9700

 Tel: +49 (0)6631 / 91-13-0

 Tel: +44 (0)1283-712862

 Tel: +33 (0)5-55-89-23-56

 Tel: +1 (854) 855 7507

• A632E30 • A647E30 • A660E30

**Strong Reliable Machines
Strong Reliable Support**

BELL