

E-series

Articulated Dump Trucks

B35E | B40E | B45E | B50E • PIN3

Stage V Certified



BELL

E is for evolution

Your business is our business. Bell Articulated Dump Trucks haul more, for longer at the lowest cost-per-ton to deliver more on your profit margins.

As a global leader in Articulated Dump Trucks, Bell Equipment brings you the world class E-series range. The evolutionary E-series is packed with class leading features that deliver production boosting payloads, lower daily operating costs, superior ride quality and uncompromised safety standards.

Bell E-series ADTs will give your business the competitive edge you need.

- Extensive use of high-strength, lightweight materials give these trucks the best payload-to-mass ratios and hauling efficiencies in each class.

- With their oscillating frame and high-floatation tyres, Bell trucks won't leave you stuck on muddy, rutted or hilly terrain.

- The redesigned sound-suppressed cab features fatigue-beating controls, advanced diagnostic monitor and a sealed switch module for convenient, fingertip operation of numerous functions.

- Fuel-efficient emission certified engines deliver clean power without compromise in all conditions. Leading-edge emissions technology ensures rapid engine response and dependable cold-start performance.



The E-series range takes ADT functionality to new industry standards, with customer-focused enhancements and the highest level of automated machine protection available.

Through substantial investments in Research and Development and employing industry leading technology, advancements in the key areas of performance and fuel efficiency – help you to move more material at lower operating costs and environmental impact.



| Specifications | B35E | B40E | B45E | B50E |
|---------------------|---|---|---|---|
| Maximum net power | 320 kW (429 hp) | 380 kW (510 hp) | 390 kW (523 hp) | 430 kW (577 hp) |
| Operating mass | | | | |
| Empty | 34 019 kg (74 999 lb) | 34 596 kg (76 273 lb) | 35 479 kg (78 217 lb) | 38 287 kg (84 408 lb) |
| Loaded | 67 519 kg (148 854 lb) | 73 596 kg (162 251 lb) | 76 479 kg (168 607 lb) | 83 687 kg (184 498 lb) |
| Rated payload | 33 500 kg (73 855 lb) | 39 000 kg (85 980 lb) | 41 000 kg (90 390 lb) | 45 400 kg (100 090 lb) |
| 2:1 heaped capacity | 20,5 m ³ (27 yd ³) | 24 m ³ (31 yd ³) | 25 m ³ (33 yd ³) | 27,5 m ³ (36 yd ³) |

Building on pedigree

Building on from the proven D-series platform, Bell Equipment's evolutionary approach to design delivers optimised power-to-weight ratio and legendary fuel efficiency.



- Automatic Traction Control (ATC) is achieved with speed sensors providing feedback to the truck on-board computer. The computer then controls differential lock activation as needed. This coupled with best in class rear suspension travel results in unparalleled off-road ability.
- Automatic retardation slows the truck when the operator backs off the accelerator pedal for more confidence on steep grades.
- An industry leading, fully automatic seven-speed planetary transmission with torque converter lock-up maximises fuel efficiency.
- High-travel suspension keeps all tyres in constant contact with the ground, for optimum traction.

- Electronic common rail fuel system provides high injection pressures even at low engine speed for improved cold-starting ability, low-speed response and reduced emissions.
- Careful engine packaging and front chassis design gives the best approach angle to allow these ADTs to attack steep terrain.
- Improved payloads, faster haul cycles and industry leading fuel economy all help you move more material at a lower-cost-per-tonne than your competitors.
- Optimised payload-to-weight ratio decreases your cost per tonne because more of your fuel cost is spent moving the material, not running the machine.

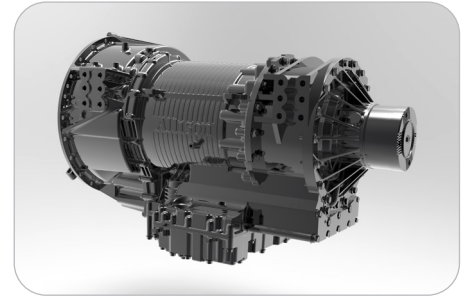

Planetary powershift transmission optimises shift points to match conditions and vehicle weight while protecting the transmission from operator error and abuse. Allison FuelSense® calibration optimises production and fuel burn.

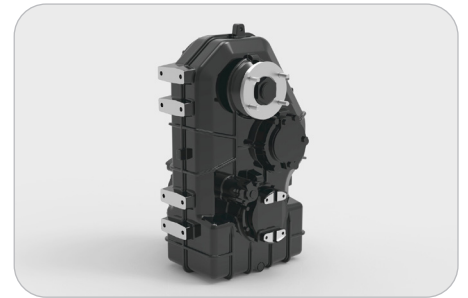

The transfer case inter-axle differential delivers equal torque to each axle when traction is favourable. When conditions deteriorate, the diff-lock automatically engages to deliver torque to the tyres that can best use it.



High-strength steel and widely spaced taper roller bearings in the articulation area enhance long-term durability.



A tailgate is available as an option for better material retention. The tailgate opens as the bin is raised for dumping. Spring steel straps maintain positive seal throughout the haul, ensuring minimal material is lost.

Our innovative front and rear comfort ride suspension options are offered to even further enhance ride quality and ensure minimal whole body vibration exposure.

Productivity increases through reduced cycle times, and reduced haul road maintenance are even further benefits of these extremely successful systems. Experienced ADT operators who have driven trucks installed with these systems have come away amazed by the comfort of the machine, as well as the confidence that the adaptive front suspension engenders.



Uncompromised durability

Built smarter, to work harder.

Bell ADTs offer optimised machine weights so you spend more time and money moving material and not running the machine.

With decades of ADT experience, the Bell E-series articulated hauler is designed and manufactured using purpose built, reliable Bell components best suited for the toughest of conditions.

The central oscillation joint, high suspension travel on all axles, and balanced weight distribution provide the agility and ability to navigate hostile terrain.

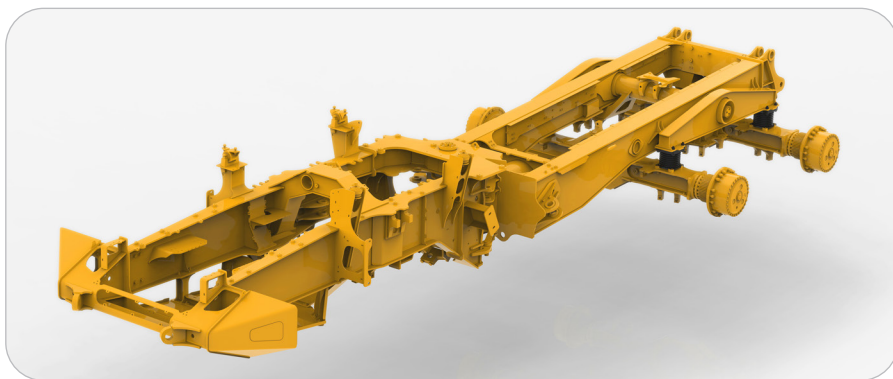

The high-strength steel chassis delivers strength and rigidity without excess weight.

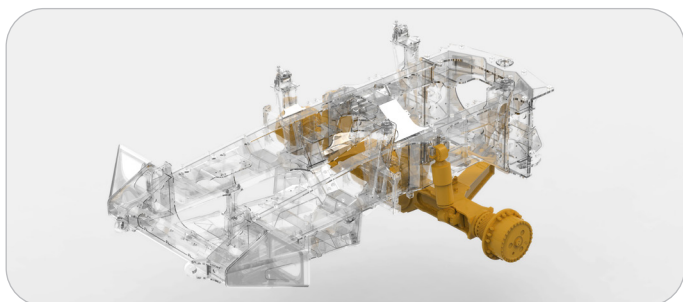

For comfortable productivity, the A-frame suspension system coupled with hydropneumatic suspension struts reduce the lateral vibration often experienced with off-road conditions. A superior suspension seat provides additional isolation for the operator.

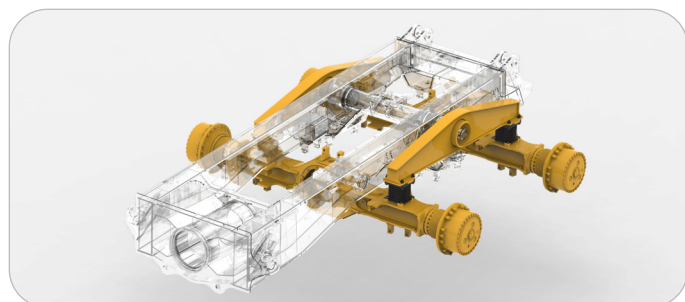

Rough terrain demands tough suspensions. Heavy-duty components absorb shocks and come back for more. You get best-in-class suspension travel and ground clearance, too.

- Fully enclosed, flooded, dual circuit wet disc brakes offer superior braking performance and extended service life essential for wet and muddy conditions. Oil-immersed wet-disc brakes are virtually maintenance-free and now feature a high flow circulation system with filtration and cooling.

- Viscous electronically controlled direct-drive engine fans provide cooling for the best efficiency.

- Class leading engine braking, coupled with automated brake retardation, provides superior braking power. Brake retardation is at pressures low enough to ensure no contact between the wet brake plates, and therefore no wear.



Other uptime-boosting features include world class on-board diagnostics with live stream functionality, solid-state sealed switches and satellite fleet management system.

High-strength welded-alloy steel chassis and reinforced articulation joints, offer superior strength and durability with optimised weight for class leading power-to-weight ratio. Lower machine mass reduces powertrain and structural stress.

Run leaner and cleaner

A combination of an optimally tuned engine and weight optimised complete machine package ensure that Bell ADTs have a minimal carbon footprint.

SCR uses AdBlue®/DEF which

- is non-toxic, odorless, low cost and simple to refill.
- is injected into the flow of the exhaust gases and reacts with the NOx gases in the catalytic converter to form harmless nitrogen and water.
- is consumed at approximately 3-5% of your fuel usage.

EGR

- recirculates burnt exhaust gas back into the combustion chamber, lowering combustion temperatures and NOx production.

DPF

- Our DPF technology has been used in Mercedes-Benz road trucks for over 10 years.
- Regeneration is done during normal operation as much as possible.
- In light applications stationary active regeneration may be necessary.



- Reduced emissions
- Improved engine efficiency
- Lower fuel consumption
- Improved power
- Improved torque
- Improved engine response

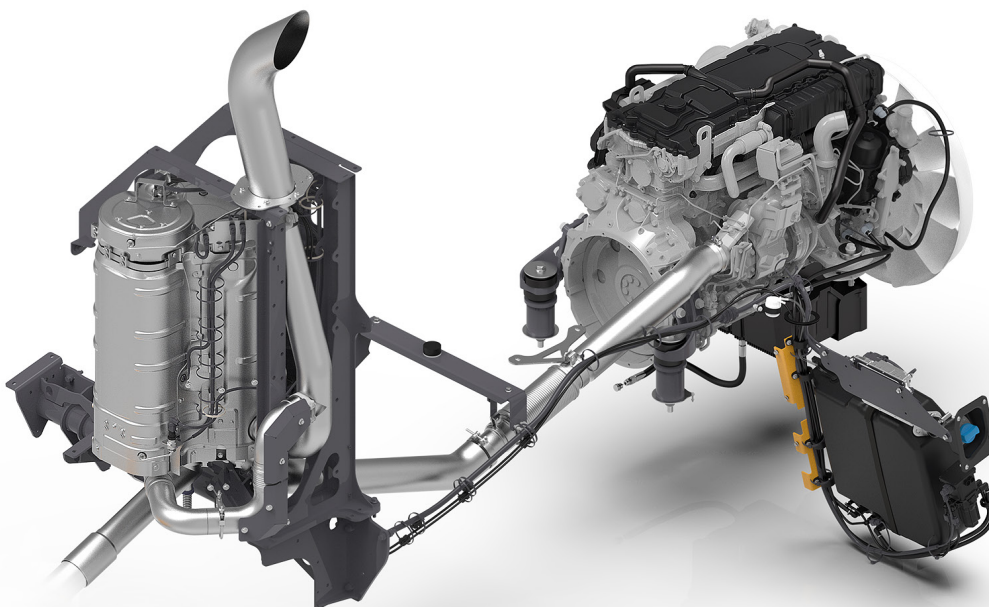



- Stage V emissions control coupled with the lowest fuel burn ensures the lowest environmental impact.

Our E-series truck platform easily accommodates current engine and related emissions control technology and reflects our strategy of continuous improvement.

Bell Equipment's evolutionary E-series runs SCR-technology (Selective Catalytic Reduction) in combination with EGR to give an industry leading standard in fuel-efficient emission control, designed specifically for the off-highway market to be compliant to Tier 4f. Engine power and fuel consumption have been further optimised through event dependent software that controls retardation, cooling and charging of accumulators.

Operate with ease

Using the latest in automotive technology and state-of-the-art tooling, the E-series takes operator experience to new heights.

Climb into the cab of a Bell ADT and you will feel right at home. Its quiet, spacious interior, ergonomically positioned operator station and climate-controlled cabin is loaded with productivity boosting comfort and convenience features that minimise operator fatigue and enhance the operator's experience.

Modern flowing lines, in keeping with current styling trends on road vehicles, offer unsurpassed levels of visibility.

From the state-of-the-art 10" full colour screen, automotive mouse interface and sealed switch module with centrally located sealed display unit to air suspension seat, tilt/telescoping steering wheel and optional CD player with high-output speakers, the E-series provides everything your operators need to perform at their best.

- The standard sound-suppression package significantly reduces noise levels and operator fatigue.

- A fully adjustable air-suspension seat with variable damping, auto height adjust according to operator weight, pneumatic lumbar support and multipoint harness for class-leading comfort and safety.

- New machine styling and cabin design improvements, which include full glass access door and high visibility mirror package, provide exceptional all-round visibility.

- The adaptive transmission control adjusts clutch engagement to ensure smooth, consistent shifts throughout the life of the truck.

- A purpose designed HVAC climate control system with automotive-style louvres keeps the glass clear and the cab comfortable.

- You won't find retarder pedals or levers in a Bell truck. Retarder aggressiveness is simply set on the switch pad. Or Hill Descent Control can set it for you automatically.



Easy-to-understand instruments and intuitive controls wrap around the operator so they're easier to view and operate.



A user friendly 10" colour monitor offers vital operating information, safety warnings, detailed diagnostic readings and dump body function settings.



An automotive controller provides menu navigation on the colour monitor to extract information on machine operation and adjustment of machine settings.



Convenient sealed switch module provides fingertip control of numerous productivity enhancing functions including: **Keyless Start, I-Tip, Dump Body Upper Limit, Soft Stop/Hard Stop Selection, Retarder Aggressiveness and Speed Control.**



Safety, our business too

By listening to users and delivering on expectations in an ever changing workplace, we provide a truck that leads in application safety with numerous groundbreaking innovations.

Independent features such as Keyless Start, Hill Assist, Bin Tip Prevention, Auto Park Application (APA), Standard Turbo Spin Protection and On-Board Weighing (OBW) are still standard on the E-series.

For improved safety and productivity, the E-series has Automatic Traction Control (ATC).

- Full handrails (to ISO 2876) can be installed to offer improved safety when performing engine checks.
- The park brake automatically applies when neutral is selected and it is not possible to engage neutral at speed. Torque dependent park brake release (Hill Assist) ensures no roll back on slopes.
- All trucks can be set up to automatically sound the horn when starting or switching between forward and reverse.

- Best-in-class retarder and engine braking automatically applies when the operator lifts his foot off the accelerator. Retarder aggressiveness can be simply adjusted on the sealed switch module ensuring maximum descent control for all conditions.
- Multiple geofencing in challenging site conditions ensures safe machine operation, such as downhill speed control, geofence speed limits and bin restrictions.



Our quiet operator cabins are ROPS/FOPS certified with an air suspension operator seat. The trainer seat has a retractable lap belt while the operator seat has a standard 3 point seat belt. Both have automatically locking retractors.



An optional integrated reverse camera and high visibility mirrors ensure superior all round visibility.



Keyless start, driver identity and access codes ensure no unauthorised operation of your equipment.

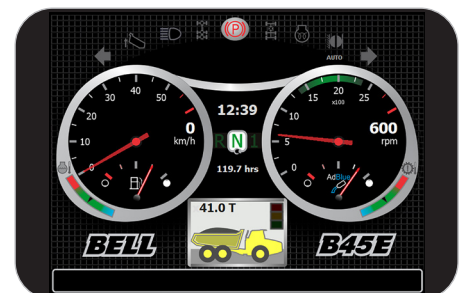

The exclusive on-board weighing presents the operator with real time information on the payload while the machine is being loaded. A 'speed restriction' mode can also be activated if the machine is significantly overloaded.

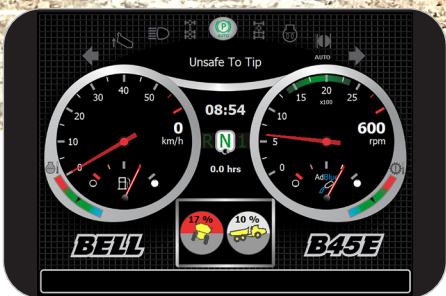

The incorporation of a pitch and roll sensor in the vehicle prevents bin operation if the truck is in an unsafe position.

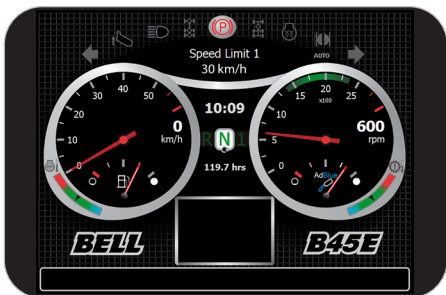

Both operator or site selectable maximum speed control allows the vehicle to automatically decelerate and apply the retarder to prevent onsite speeding.



Maximise your uptime

The E-series is loaded with features that make it as easy to maintain as it is to operate. Spend less time and expense getting ready for work and more time getting work done.

Easy-to-reach dipsticks, see-through reservoirs, sight gauges and grouped service points make quick work of the daily routine. Quick change filters, extended engine and hydraulic oil-service intervals lower daily operating costs and provide superior machine uptime.

An industry leading 10" colour monitor offers on-board machine diagnostics as well as automated daily service functionality, this coupled with diagnostic test ports help you troubleshoot and make informed maintenance decisions on site.

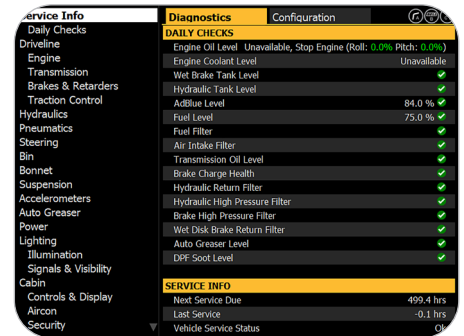

If something goes wrong, the diagnostic monitor provides service codes and supporting info to help diagnose the problem.



The cab can be tilted in minutes without special tools, for convenient service access to drivetrain components.



An in-cab load centre simplifies fuse replacement. Fewer relays, connectors and harnesses mean higher reliability.



We offer a remote transmission filter option. They make transmission filter replacement a fast and clean task.

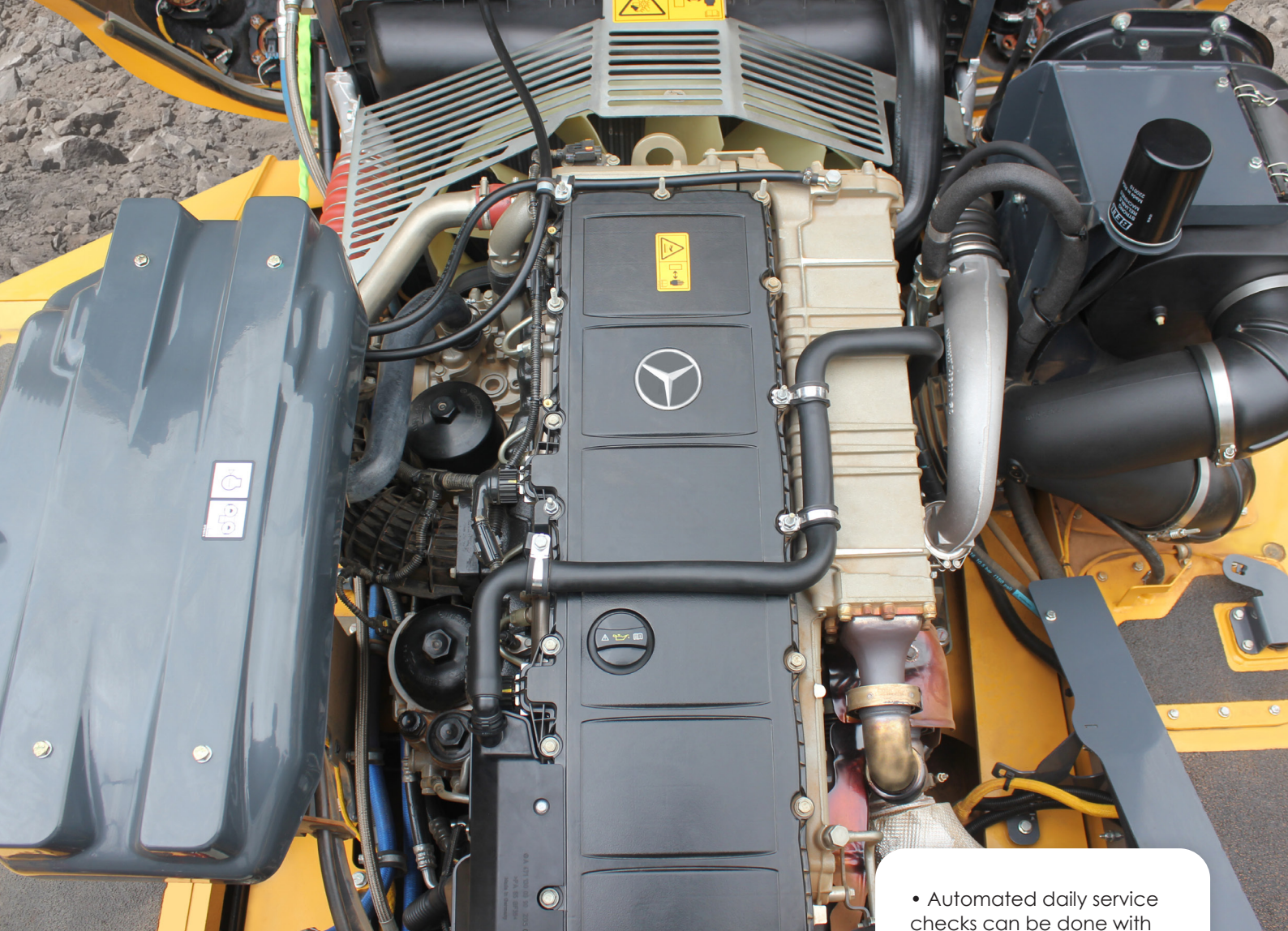

- Automated daily service checks can be done with ease and comfort from inside the operator station using the 10" colour LCD monitor and sealed display controller.

- The load-sensing hydraulic system was designed with simplicity in mind, while maintaining efficiency. Fewer components for improved reliability and serviceability.

- Extended engine transmission and hydraulic oil-change for increased uptime and lower operating cost.

- Available environmental drains allow quick, no-spill changes.

- Your Bell Service Centre has the parts and backup you need to stay productive and offers a wide variety of preventative maintenance and support programmes to help you control costs.



See-through fluid reservoirs and sight gauges let you check fluid levels at a glance.



Easily accessible test ports allow technicians to troubleshoot problems more quickly.



The centralised lube bank places difficult-to-reach grease points within reach.

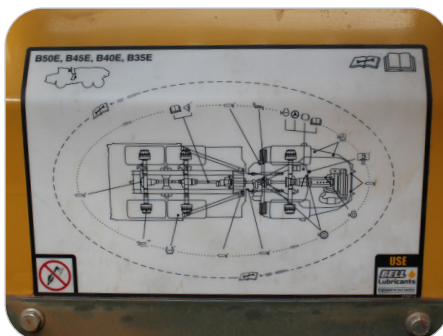

The convenient and easy to understand RSG decal details daily checks and actions (eg: greasing).

Welcome to the ...

BELL Family

“Power up and plug in to our end-to-end customer solutions!”

START

Through our living motto **‘Strong Reliable Machines, Strong Reliable Support’**, we offer both exceptional equipment and aftermarket support products because we want your Bell ownership experience to be a happy one.

SETTING YOU UP FOR SUCCESS

TRAINING

PROTECTING YOUR ASSETS

LUBE CHECK

MAINTENANCE CONTRACT

EXTENDED WARRANTY

FLEETM@TIC®

KEEPING YOUR MACHINE RUNNING

LUBRICANTS

PARTS

SERVICE KITS

TECHNICAL SUPPORT

SPECIAL TOOLS

BELL OUTLETS

GIVING YOU EXTRA VALUE, LONGER LIFE

REMAN COMPONENTS

PRE-OWNED EQUIPMENT

SUPPORTING YOU EVERY STEP OF YOUR BELL OWNERSHIP EXPERIENCE

Smarter fleet management



Cutting edge technology, helping you run your fleet smarter. Providing accurate, up-to-date operational data, production data and diagnostic data.

The key to a productive and profitable fleet, lies in the ability to monitor and manage your machines and operators efficiently. Machine operational data is processed and compiled into useful production and performance statistics, accessible via the Bell Fleetm@tic® website. These reports are also automated and emailed directly to you. The two monitoring packages that we have available, are:

- **The Classic Package** supplies you with good enough information for you to have a very good understanding of how your machine is operating for each shift that it runs. This package comes standard with the machine for 2 years.
- **The Premium Package** is focused on customers who need to have extremely detailed information of the machine's operation. For this package we offer similar information to that of the Classic Package but for each individual laden - unladen cycle. In addition, live tracking is available on the Fleetm@tic® website on a per minute basis.

Fleetm@tic®:

- Maximise productivity
- Generate machine utilisation reports
- Identify operator training requirements
- Pro-active maintenance planning
- Implement safety features
- Receive machine fault codes as well as suggested trouble shooting procedures
- Protect investments
- Receive real time geospatial data



B35E Articulated Dump Truck

ENGINE

Manufacturer
Mercedes Benz (MTU)

Model
OM471LA (MTU 6R 1300)

Configuration
Inline 6, turbocharged and intercooled.

Maximum Net Power
320 kW (429 hp) at 1 600 rpm in accordance with UN ECE R120

Gross Torque
2 600 Nm (1 917 lbf) @ 1 300 rpm

Displacement
12,8 litres (781 cu.in)

Auxiliary Brake
Jacobs Engine Brake®

Fuel Tank Capacity
352 litres (93 US gal)

AdBlue® Tank Capacity
40 litres (11 US gal)

Certification
OM471LA (MTU 6R 1300) meets EU Stage V / EPA Tier 4 Final emissions regulations.

TRANSMISSION

Manufacturer
Allison

Model
4700 ORS

Configuration
Fully automatic planetary transmission.

Layout
Engine mounted

Gear Layout
Constant meshing planetary gears, clutch operated

Gears
7 Forward, 1 Reverse

Clutch Type
Hydraulically operated multi-disc

Control Type
Electronic

Torque Control
Hydrodynamic with lock-up in all gears.

TRANSFER CASE

Manufacturer
Kessler

Series
W2400

Layout
Remote mounted

Gear Layout
Three in-line helical gears

Output Differential
Interaxle 29/71 proportional differential. Automatic inter-axle differential lock.

AXLES

Manufacturer
Bell

Model
30T

Differential
High input controlled traction differential with spiral bevel gears

Final Drive
Outboard heavy duty planetary on all axles.

BRAKING SYSTEM

Service Brake
Dual circuit, full hydraulic actuation wet disc brakes on front and middle axles. Wet brake oil is circulated through a filtration and cooling system.

Maximum brake force:
352 kN (79 133 lbf)

Park & Emergency
Spring applied, air released driveline mounted disc.

Maximum brake force:
206 kN (46 311 lbf)

Auxiliary Brake
Jacobs Engine Brake®. Automatic retardation through electronic activation of wet brake system.

Total Retardation Power
Continuous: 442 kW (593 hp)
Maximum: 834 kW (1 118 hp)

WHEELS

Type
Radial Earthmover

Tyre
26.5 R 25

FRONT SUSPENSION

Semi-independent, leading A-frame supported by hydro-pneumatic suspension struts
Optional active dual springrate Comfort Ride suspension available, including height control.

REAR SUSPENSION

Pivoting walking beams with laminated rubber suspension blocks.
Optional passive dual-springrate Comfort Ride walking beam available.

HYDRAULIC SYSTEM

Full load sensing system serving the prioritized steering, body tipping and brake functions. A ground-driven, load sensing emergency steering pump is integrated into the main system.

Pump Type
Variable displacement load sensing piston

Flow
300 L/min (79 gal/min)

Pressure
310 Bar (4 500 psi)

Filter
5 microns

STEERING SYSTEM

Double acting cylinders, with ground-driven emergency steering pump.

Lock to lock turns
4.5

Steering Angle
42°

DUMPING SYSTEM

Two double-acting, single stage, dump cylinders.

Raise Time
12 seconds

Lowering Time
11 seconds

Tipping Angle
70 deg standard, or any lower angle programmable

PNEUMATIC SYSTEM

Air drier with heater and integral unloader valve, serving park brake and auxiliary functions.

System Pressure
8,1 Bar (117 psi)

ELECTRICAL SYSTEM

Voltage
24 V

Battery Type
Two AGM (Absorption Glass Mat) type.

Battery Capacity
2 X 75 Ah

Alternator Rating
28V 100A

MAX. VEHICLE SPEED

| | | |
|-----|---------|--------|
| 1st | 4 km/h | 3 mph |
| 2nd | 9 km/h | 6 mph |
| 3rd | 16 km/h | 10 mph |
| 4th | 22 km/h | 14 mph |
| 5th | 31 km/h | 19 mph |
| 6th | 42 km/h | 26 mph |
| 7th | 48 km/h | 30 mph |
| R | 7 km/h | 4 mph |

CAB

ROPS/FOPS certified
77 dBA internal sound pressure measured according to ISO 6396.

Load Capacity & Ground Pressure

| OPERATING WEIGHTS | | GROUND PRESSURE* | | | | LOAD CAPACITY | | OPTION WEIGHTS | |
|-------------------|------------------|---|--|------------------|------------|--------------------------------|-----------------------------------|-----------------------|-------------|
| UNLADEN | kg (lb) | LADEN | | | | BODY | m ³ (yd ³) | kg (lb) | |
| Front | 16 816 (37 073) | No sinkage/Total Contact Area (as recommended by tyre manufacturer) | Calculation method used by competition | Struck Capacity | | 16 (21) | Bin liner | 1 216 (2 681) | |
| Middle | 8 708 (19 198) | | | SAE 2:1 Capacity | | 20,5 (27) | Tailgate | 924 (2 037) | |
| Rear | 8 495 (18 728) | 26,5 R 25 | kPa (Psi) | 26,5 R 25 | kPa (Psi) | SAE 1:1 Capacity | 24,5 (32) | | |
| Total | 34 019 (74 999) | Front | 376 (54,5) | Front | 167 (24,2) | SAE 2:1 Capacity with Tailgate | 21 (28) | EXTRA WHEELSET | |
| LADEN | | Mid/Rear | 382 (55,4) | Rear | 181 (26,3) | | | 26,5 R 25 | |
| Front | 20 770 (45 790) | | | | | | | (per vehicle) Add | 330 (727,5) |
| Middle | 23 481 (51 767) | | | | | Rated Payload | 33 500 kg | | |
| Rear | 23 268 (51 297) | | | | | | (73 855 lb) | | |
| Total | 67 519 (148 854) | | | | | | | | |

* All Ground pressures calculated with Michelin XADN+ Tyre

Dimensions

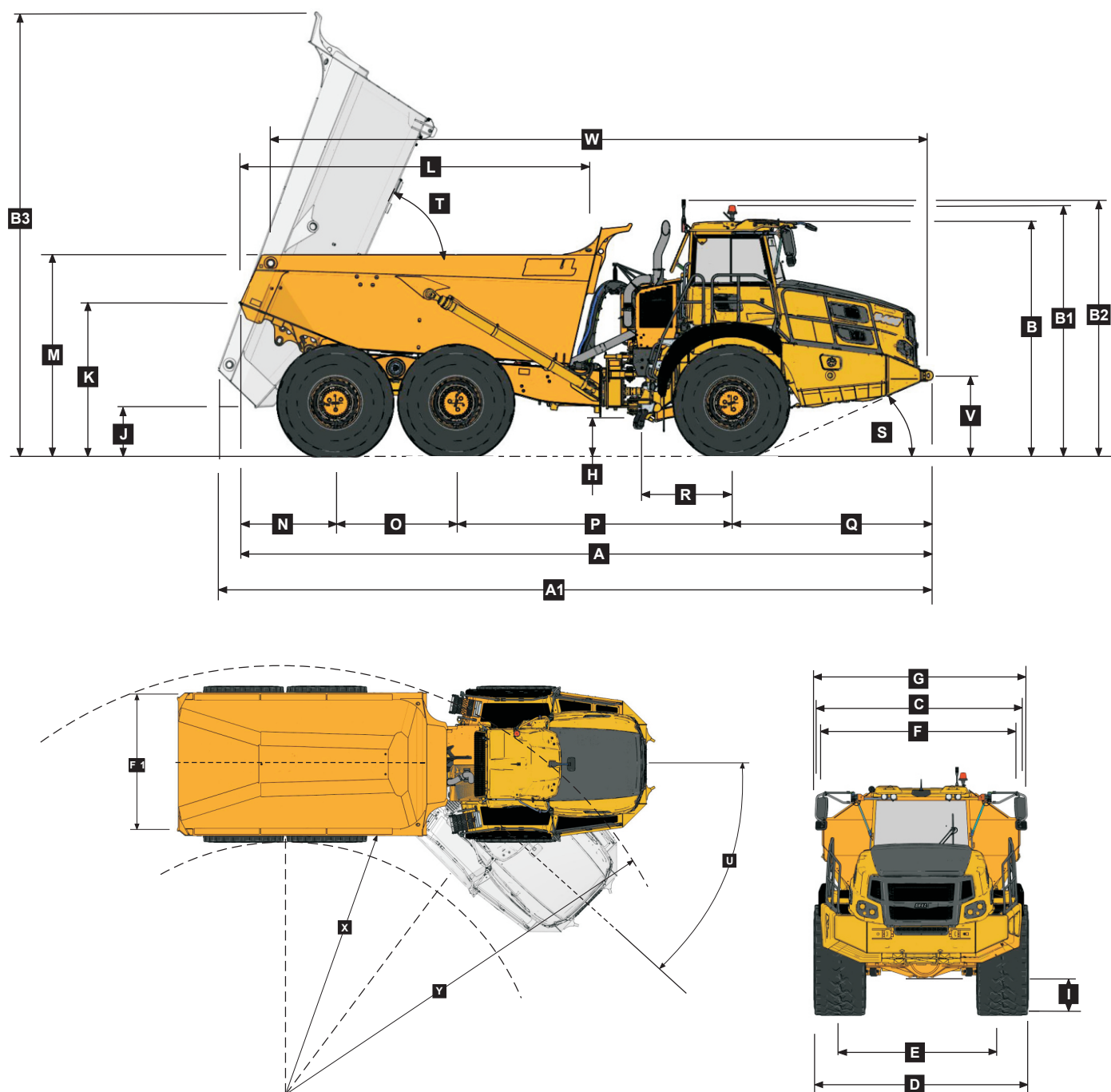

Machine Dimensions

| | | | | | | | |
|----|---|-----------|-----------------|---|---------------------------------------|-----------|-----------------|
| A | Length - Transport Position with Tailgate | 11 268 mm | (37 ft.) | K | Bin Lip Height - Transport Position | 2 463 mm | (8 ft. 1 in.) |
| A | Length - Transport Position w/o Tailgate | 11 188 mm | (36 ft. 8 in.) | L | Bin Length | 5 709 mm | (18 ft. 9 in.) |
| A1 | Length - Bin Fully Tipped | 11 631 mm | (38 ft. 2 in.) | M | Load over Height | 3 084 mm | (10 ft. 1 in.) |
| B | Height - Transport Position | 3 752 mm | (12 ft. 4 in.) | N | Rear Axle Centre to Bin Rear | 1 545 mm | (5 ft.) |
| B1 | Height - Rotating Beacon | 3 988 mm | (13 ft. 1 in.) | O | Mid Axle Centre to Rear Axle Centre | 1 950 mm | (6 ft. 5 in.) |
| B2 | Height - Load Light | 4 076 mm | (13 ft. 4 in.) | P | Mid Axle Centre to Front Axle Centre | 4 438 mm | (14 ft. 7 in.) |
| B3 | Bin Height - Fully Tipped | 7 213 mm | (23 ft. 8 in.) | Q | Front Axle Centre to Machine Front | 3 255 mm | (10 ft. 8 in.) |
| C | Width over Mudguards | 3 495 mm | (11 ft. 6 in.) | R | Front Axle Centre to Artic Centre | 1 558 mm | (5 ft. 1 in.) |
| D | Width over Tyres - 26.5R25 | 3 438 mm | (11 ft. 3 in.) | S | Approach Angle | 23 ° | |
| E | Tyre Track Width - 26.5R25 | 2 768 mm | (9 ft. 1 in.) | T | Maximum Bin Tip Angle | 70 ° | |
| F | Width over Bin | 3 112 mm | (10 ft. 3 in.) | U | Maximum Articulation Angle | 42 ° | |
| F1 | Width over Tailgate | 3 402 mm | (11 ft. 2 in.) | V | Front Tie Down Height | 1 215 mm | (4 ft.) |
| G | Width over Mirrors - Operating Position | 3 614 mm | (11 ft. 10 in.) | W | Machine Lifting Centres | 10 655 mm | (34 ft. 11 in.) |
| H | Ground Clearance - Artic | 493 mm | (19.41 in.) | X | Inner Turning Circle Radius - 26.5R25 | 4 891 mm | (16 ft.) |
| I | Ground Clearance - Front Axle | 493 mm | (19.41 in.) | Y | Outer Turning Circle Radius - 26.5R25 | 9 211 mm | (30 ft. 3 in.) |
| J | Ground Clearance - Bin Fully Tipped | 822 mm | (32.4 in.) | | | | |

Gradeability/Rimpull

1. Determine tractive resistance by finding intersection of vehicle mass line and grade line. NOTE: 2% typical rolling resistance is already assumed in chart and grade line.
2. From this intersection, move straight right across charts until line intersects rimpull curve.
3. Read down from this point to determine maximum speed attained at that tractive resistance.

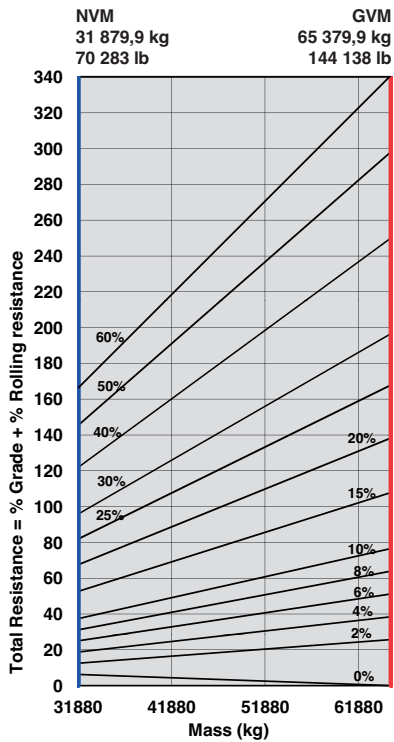

ADT, B35E 6X6 - Tractive Effort

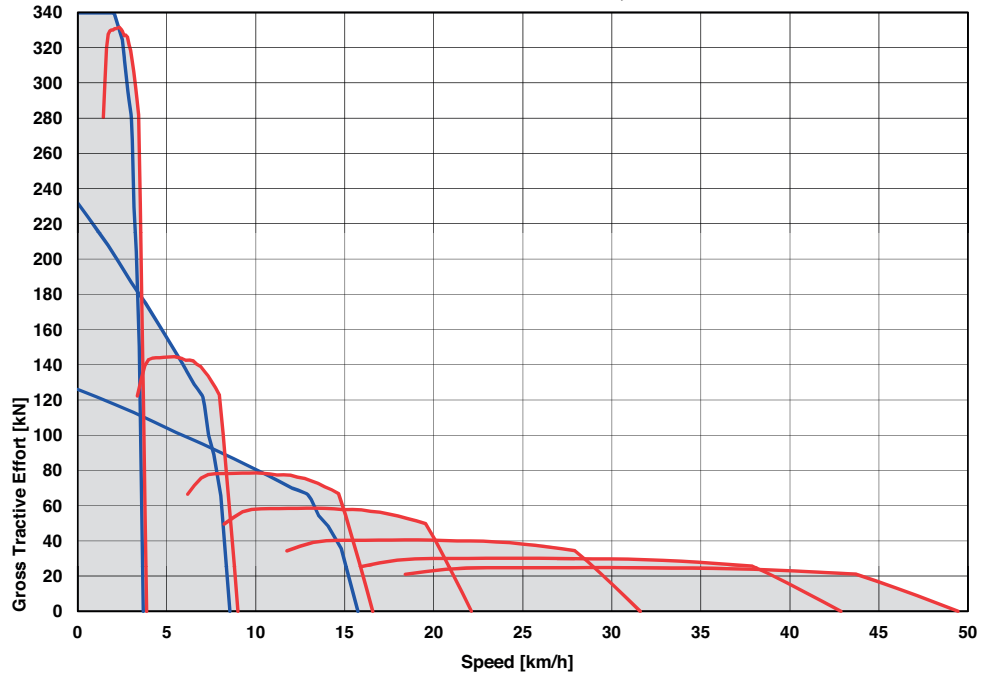

Retardation

1. Determine retardation force required by finding intersection of vehicle mass line.
2. From this intersection, move straight right across charts until line intersects the curve. NOTE: 2% typical rolling resistance is already assumed in chart.
3. Read down from this point to determine maximum speed.

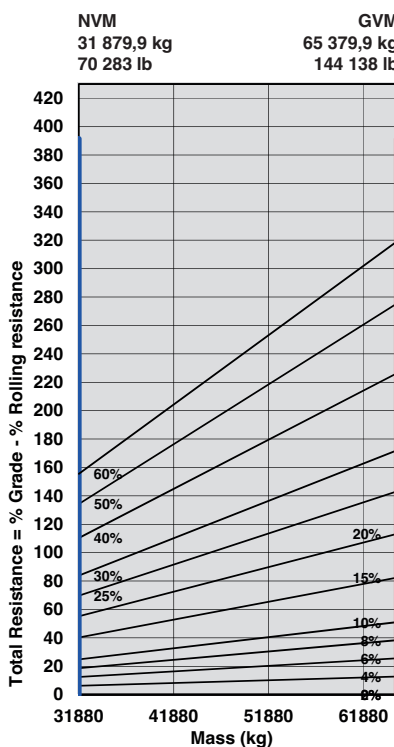

ADT, B35E 6X6 - Retardation

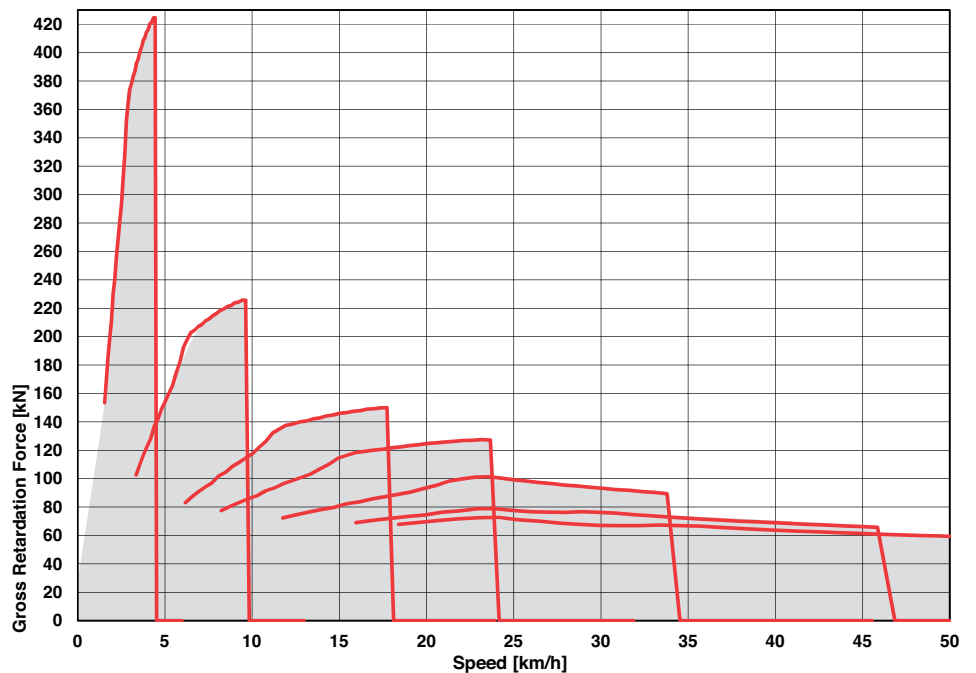

B40E Articulated Dump Truck

| | | | | | | | | | | | | | | | | | | | | | | | | | | | |
|---|--|--|---|-----|--------|---------|-----|--------|-------|-----|---------|--------|-----|---------|--------|-----|---------|--------|-----|---------|----------|-----|---------|--------|---|--------|-------|
| ENGINE Manufacturer Mercedes Benz (MTU) Model OM471LA (MTU 6R 1300) Configuration Inline 6, turbocharged and intercooled. Maximum Net Power 380 kW (510 hp) at 1 600 rpm in accordance with UN ECE R120 Gross Torque 2 600 Nm (1 917 lbf) @ 1 300 rpm Displacement 12,8 litres (781 cu.in) Auxiliary Brake Jacobs Engine Brake® Fuel Tank Capacity 443 liters (117 US gal) AdBlue® Tank Capacity 40 litres (11 US gal) Certification OM471LA (MTU 6R 1300) meets EU Stage V / EPA Tier 4 Final emissions regulations | TRANSFER CASE Manufacturer Kessler Series W2400 Layout Remote mounted Gear Layout Three in-line helical gears Output Differential Interaxle 29/71 proportional differential. Automatic inter-axle differential lock. | WHEELS Type Radial Earthmover Tyre 29.5 R 25 (875/65 R 29 optional) | DUMPING SYSTEM Two double-acting, single stage, dump cylinders. Raise Time 12 seconds Lowering Time 11 seconds Tipping Angle 70 deg standard, or any lower angle programmable | | | | | | | | | | | | | | | | | | | | | | | | |
| TRANSMISSION Manufacturer Allison Model 4700 ORS Configuration Fully automatic planetary transmission. Layout Engine mounted Gear Layout Constant meshing planetary gears, clutch operated Gears 7 Forward, 1 Reverse Clutch Type Hydraulically operated multi-disc Control Type Electronic Torque Control Hydrodynamic with lock-up in all gears. | AXLES Manufacturer Bell Model 30T Differential High input controlled traction differential with spiral bevel gears Final Drive Outboard heavy duty planetary on all axles. | FRONT SUSPENSION Semi-independent, leading A-frame supported by hydro-pneumatic suspension struts. REAR SUSPENSION Pivoting walking beams with laminated rubber suspension blocks. HYDRAULIC SYSTEM Full load sensing system serving the prioritized steering, body tipping and brake functions. A ground-driven, load sensing emergency steering pump is integrated into the main system. | PNEUMATIC SYSTEM Air drier with heater and integral unloader valve, serving park brake and auxiliary functions. ELECTRICAL SYSTEM Voltage 24 V Battery Type Two AGM (Absorption Glass Mat) type. Battery Capacity 2 X 75 Ah Alternator Rating 28V 100A | | | | | | | | | | | | | | | | | | | | | | | | |
| | BRAKING SYSTEM Service Brake Dual circuit, full hydraulic actuation wet disc brakes on front and middle axles. Wet brake oil is circulated through a filtration and cooling system. Park & Emergency Spring applied, air released driveline mounted disc. Auxiliary Brake Jacobs Engine Brake®. Automatic retardation through electronic activation of wet brake system. | REAR SUSPENSION Pivoting walking beams with laminated rubber suspension blocks. HYDRAULIC SYSTEM Full load sensing system serving the prioritized steering, body tipping and brake functions. A ground-driven, load sensing emergency steering pump is integrated into the main system. | MAX. VEHICLE SPEED <table border="1"> <tr><td>1st</td><td>4 km/h</td><td>2,5 mph</td></tr> <tr><td>2nd</td><td>9 km/h</td><td>6 mph</td></tr> <tr><td>3rd</td><td>17 km/h</td><td>11 mph</td></tr> <tr><td>4th</td><td>23 km/h</td><td>14 mph</td></tr> <tr><td>5th</td><td>33 km/h</td><td>21 mph</td></tr> <tr><td>6th</td><td>44 km/h</td><td>27,3 mph</td></tr> <tr><td>7th</td><td>51 km/h</td><td>32 mph</td></tr> <tr><td>R</td><td>7 km/h</td><td>4 mph</td></tr> </table> | 1st | 4 km/h | 2,5 mph | 2nd | 9 km/h | 6 mph | 3rd | 17 km/h | 11 mph | 4th | 23 km/h | 14 mph | 5th | 33 km/h | 21 mph | 6th | 44 km/h | 27,3 mph | 7th | 51 km/h | 32 mph | R | 7 km/h | 4 mph |
| 1st | 4 km/h | 2,5 mph | | | | | | | | | | | | | | | | | | | | | | | | | |
| 2nd | 9 km/h | 6 mph | | | | | | | | | | | | | | | | | | | | | | | | | |
| 3rd | 17 km/h | 11 mph | | | | | | | | | | | | | | | | | | | | | | | | | |
| 4th | 23 km/h | 14 mph | | | | | | | | | | | | | | | | | | | | | | | | | |
| 5th | 33 km/h | 21 mph | | | | | | | | | | | | | | | | | | | | | | | | | |
| 6th | 44 km/h | 27,3 mph | | | | | | | | | | | | | | | | | | | | | | | | | |
| 7th | 51 km/h | 32 mph | | | | | | | | | | | | | | | | | | | | | | | | | |
| R | 7 km/h | 4 mph | | | | | | | | | | | | | | | | | | | | | | | | | |
| | Total Retardation Power Continuous: 442 kW (593 hp) Maximum: 854 kW (1 145 hp) | STEERING SYSTEM Double acting cylinders, with ground-driven emergency steering pump. Lock to lock turns 4,5 Steering Angle 42° | CAB ROPS/FOPS certified 77 dBA internal sound pressure measured according to ISO 6396. | | | | | | | | | | | | | | | | | | | | | | | | |

Load Capacity & Ground Pressure

| OPERATING WEIGHTS | | GROUND PRESSURE* | | | | LOAD CAPACITY | | OPTION WEIGHTS | |
|-------------------|------------------|---|--|------------------|------------|--------------------------------|-----------------------|-----------------------|---------------|
| UNLADEN | kg (lb) | LADEN | | LADEN | | BODY | m³ (yd³) | kg (lb) | |
| Front | 16 816 (37 072) | No sinkage/Total Contact Area (as recommended by tyre manufacturer) | Calculation method used by competition | 29.5 R 25 | kPa (Psi) | Struck Capacity | 19 (25) | Bin liner | 1 369 (3 018) |
| Middle | 8 997 (19 834) | | | 29.5 R 25 | kPa (Psi) | SAE 2:1 Capacity | 24 (31) | Tailgate | 1 002 (2 209) |
| Rear | 8 784 (19 365) | 29.5 R 25 | kPa (Psi) | SAE 1:1 Capacity | 28,5 (37) | Wheelset 875/65 R29 | | | |
| Total | 34 596 (76 271) | Front | 310 (45) | Front | 151 (21,9) | SAE 2:1 Capacity with Tailgate | 24,5 (32) | (per vehicle) Add | 1 338 (2 950) |
| LADEN | | Mid/Rear | 367 (53,2) | Rear | 169 (24,5) | Rated Payload | 39 000 kg (85 980 lb) | EXTRA WHEELSET | |
| Front | 21 691 (47 820) | | | | | | | 29.5 R 25 | |
| Middle | 26 059 (57 450) | 875/65 R29 | | 875/65 R29 | | | | (per vehicle) Add | 516 (1 138) |
| Rear | 25 846 (56 981) | Front | 293 (42,5) | Front | 131 (19) | | | 875/65 R29 | |
| Total | 73 596 (162 251) | Mid/Rear | 329 (47,7) | Rear | 149 (21,6) | | | (per vehicle) Add | 1 338 (2 950) |

* 29.5R25 Ground pressures calculated with Michelin XADN+ Tyre. 875/65R29 Groundpressures calculated with Michelin XAD65-1 Tyre.

B40E

Dimensions

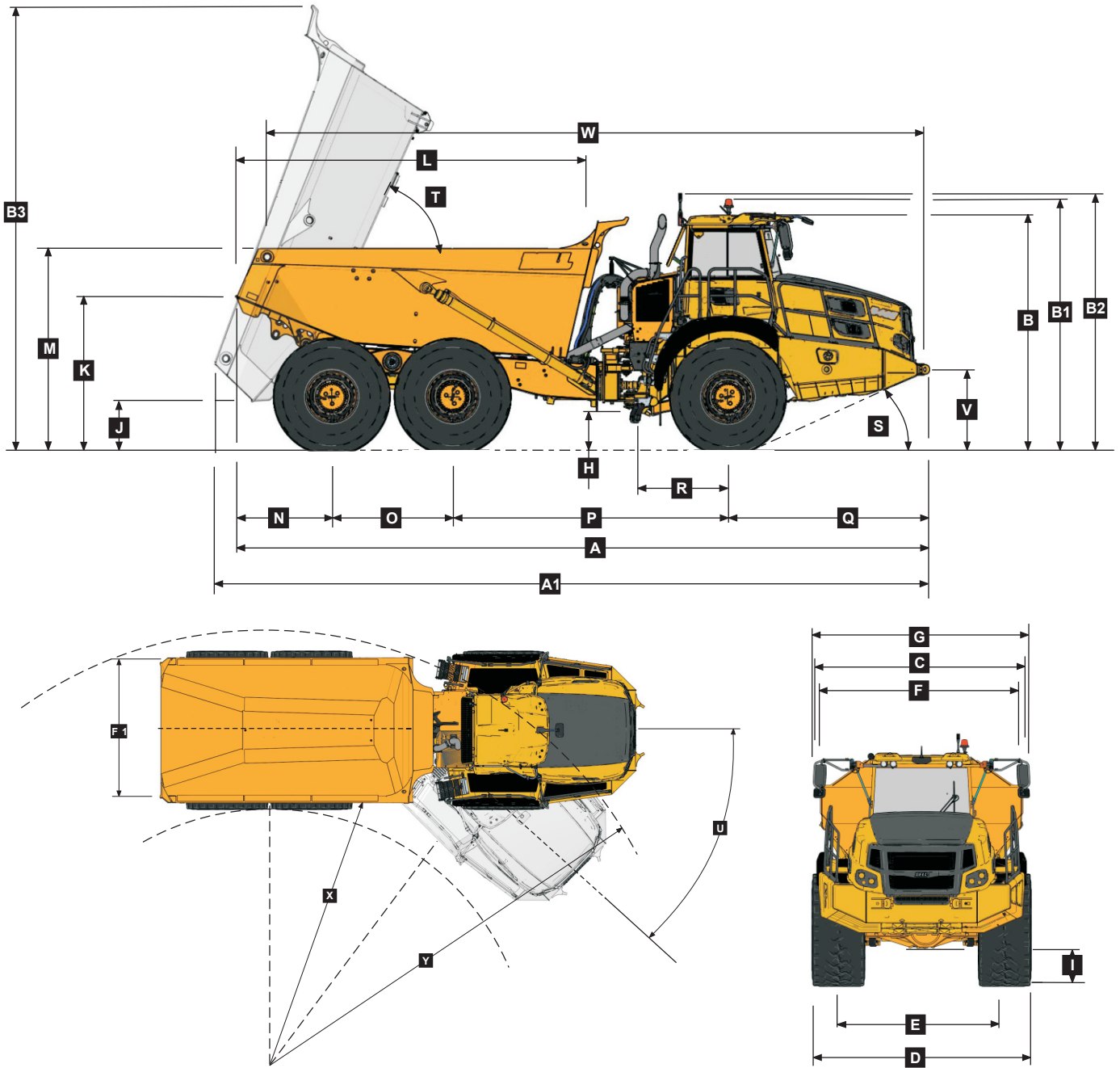

Machine Dimensions

| | | | | | |
|----|---|--------------------------|---|--|--------------------------|
| A | Length - Transport Position with Tailgate | 11 197 mm (36 ft. 9 in.) | K | Bin Lip Height - Transport Position | 2 519 mm (8 ft. 3 in.) |
| A | Length - Transport Position w/o Tailgate | 11 186 mm (36 ft. 8 in.) | L | Bin Length | 5 742 mm (18 ft. 10 in.) |
| A1 | Length - Bin Fully Tipped | 11 742 mm (38 ft. 6 in.) | M | Load over Height | 3 271 mm (10 ft. 9 in.) |
| B | Height - Transport Position | 3 804 mm (12 ft. 6 in.) | N | Rear Axle Centre to Bin Rear | 1 543 mm (5 ft.) |
| B1 | Height - Rotating Beacon | 4 040 mm (13 ft. 3 in.) | O | Mid Axle Centre to Rear Axle Centre | 1 950 mm (6 ft. 5 in.) |
| B2 | Height - Load Light | 4 129 mm (13 ft. 7 in.) | P | Mid Axle Centre to Front Axle Centre | 4 438 mm (14 ft. 7 in.) |
| B3 | Bin Height - Fully Tipped | 7 316 mm (24 ft.) | Q | Front Axle Centre to Machine Front | 3 255 mm (10 ft. 8 in.) |
| C | Width over Mudguards | 3 495 mm (11 ft. 6 in.) | R | Front Axle Centre to Artic Centre | 1 558 mm (5 ft. 1 in.) |
| D | Width over Tyres - 875/65 R29 | 3 656 mm (12 ft.) | S | Approach Angle | 24° |
| D | Width over Tyres - 29.5R25 | 3 487 mm (11 ft. 5 in.) | T | Maximum Bin Tip Angle | 70° |
| E | Tyre Track Width - 875/65 R29 | 2 773 mm (9 ft. 1 in.) | U | Maximum Articulation Angle | 42° |
| E | Tyre Track Width - 29.5R25 | 2 725 mm (8 ft. 11 in.) | V | Front Tie Down Height | 1 265 mm (4 ft. 2 in.) |
| F | Width over Bin | 3 372 mm (11 ft.) | W | Machine Lifting Centres | 10 594 mm (34 ft. 9 in.) |
| F1 | Width over Tailgate | 3 662 mm (12 ft.) | X | Inner Turning Circle Radius - 875/65 R29 | 4 782 mm (15 ft. 8 in.) |
| G | Width over Mirrors - Operating Position | 3 614 mm (11 ft. 10 in.) | X | Inner Turning Circle Radius - 29.5R25 | 4 866 mm (16 ft.) |
| H | Ground Clearance - Artic | 545 mm (21.46 in.) | Y | Outer Turning Circle Radius - 875/65 R29 | 9 320 mm (30 ft. 7 in.) |
| I | Ground Clearance - Front Axle | 545 mm (21.46 in.) | Y | Outer Turning Circle Radius - 29.5R25 | 9 235 mm (30 ft. 4 in.) |
| J | Ground Clearance - Bin Fully Tipped | 876 mm (34.5 in.) | | | |

Gradeability/Rimpull

1. Determine tractive resistance by finding intersection of vehicle mass line and grade line. NOTE: 2% typical rolling resistance is already assumed in chart and grade line.
2. From this intersection, move straight right across charts until line intersects rimpull curve.
3. Read down from this point to determine maximum speed attained at that tractive resistance.

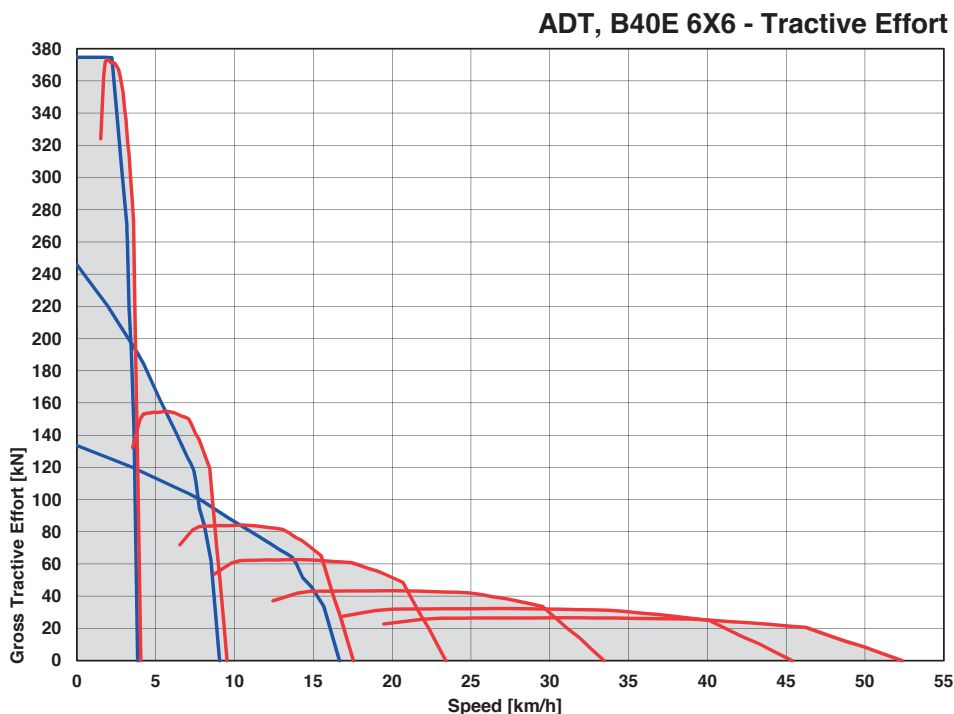
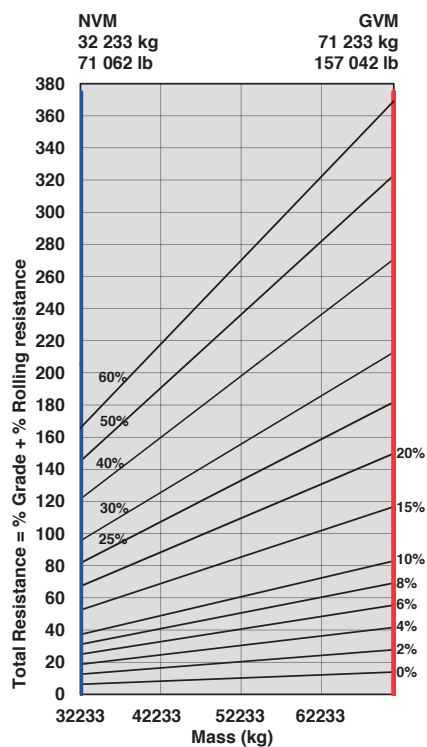

Retardation

1. Determine retardation force required by finding intersection of vehicle mass line.
2. From this intersection, move straight right across charts until line intersects the curve. NOTE: 2% typical rolling resistance is already assumed in chart.
3. Read down from this point to determine maximum speed.

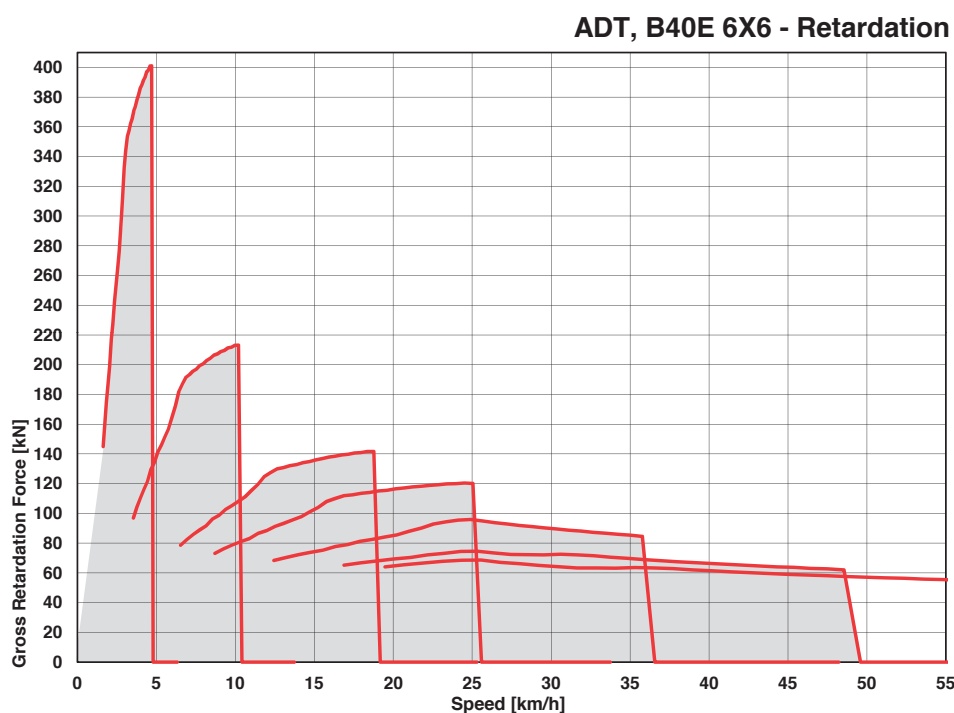
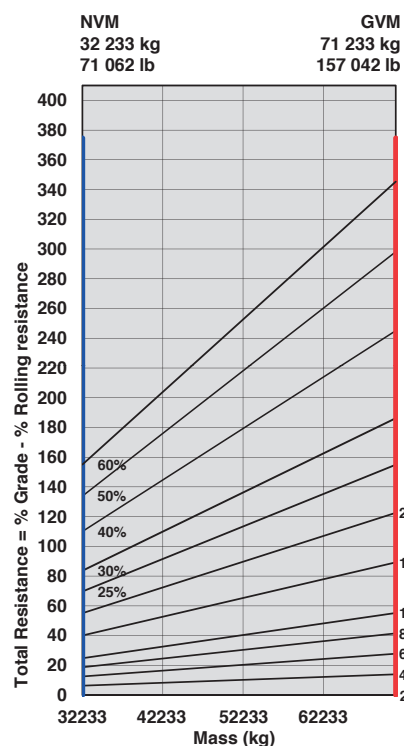

B45E Articulated Dump Truck

| | | | | | | | | | | | | | | | | | | | | | | | | | | | |
|---|--|---|---|-----|--------|---------|-----|--------|-------|-----|---------|--------|-----|---------|--------|-----|---------|--------|-----|---------|----------|-----|---------|--------|---|--------|-------|
| ENGINE Manufacturer Mercedes Benz (MTU) Model OM471LA (MTU 6R 1300) Configuration Inline 6, turbocharged and intercooled. Maximum Net Power 390 kW (523 hp) at 1 600 rpm in accordance with UN ECE R120 Gross Torque 2 600 Nm (1 917 lbf) @ 1 300 rpm Displacement 12,8 litres (781 cu.in) Auxiliary Brake Jacobs Engine Brake® Fuel Tank Capacity 443 liters (117 US gal) AdBlue® Tank Capacity 40 litres (11 US gal) Certification OM471LA (MTU 6R 1300) meets EU Stage V / EPA Tier 4 Final emissions regulations | TRANSFER CASE Manufacturer Kessler Model W2400 Layout Remote mounted Gear Layout Three in-line helical gears Output Differential Interaxle 29/71 proportional differential. Automatic inter-axle differential lock. | WHEELS Type Radial Earthmover Tyre 29.5 R 25 (875/65 R 29 optional) | DUMPING SYSTEM Two double-acting, single stage, dump cylinders. Raise Time 12 seconds Lowering Time 11 seconds Tipping Angle 70 deg standard, or any lower angle programmable | | | | | | | | | | | | | | | | | | | | | | | | |
| TRANSMISSION Manufacturer Allison Model 4700 ORS Configuration Fully automatic planetary transmission. Layout Engine mounted Gear Layout Constant meshing planetary gears, clutch operated Gears 7 Forward, 1 Reverse Clutch Type Hydraulically operated multi-disc Control Type Electronic Torque Control Hydrodynamic with lock-up in all gears. | AXLES Manufacturer Bell Model 30T Differential High input controlled traction differential with spiral bevel gears Final Drive Outboard heavy duty planetary on all axles. | FRONT SUSPENSION Semi-independent, leading A-frame supported by hydro-pneumatic suspension struts. Optional active dual springrate Comfort Ride suspension available, including height control. REAR SUSPENSION Pivoting walking beams with laminated rubber suspension blocks. Optional passive dual-springrate Comfort Ride walking beam available. | PNEUMATIC SYSTEM Air drier with heater and integral unloader valve, serving park brake and auxiliary functions. System Pressure 8,1 Bar (117 psi) | | | | | | | | | | | | | | | | | | | | | | | | |
| | BRAKING SYSTEM Service Brake Dual circuit, full hydraulic actuation wet disc brakes on front and middle axles. Wet brake oil is circulated through a filtration and cooling system. Maximum brake force: 327 kN (73 513 lbf) Park & Emergency Spring applied, air released driveline mounted disc. Maximum brake force: 218 kN (49 008 lbf) Auxiliary Brake Jacobs Engine Brake®. Automatic retardation through electronic activation of wet brake system. Total Retardation Power Continuous: 442 kW (593 hp) Maximum: 854 kW (1 145 hp) | HYDRAULIC SYSTEM Full load sensing system serving the prioritized steering, body tipping and brake functions. A ground-driven, load sensing emergency steering pump is integrated into the main system. Pump Type Variable displacement load sensing piston Flow 300 L/min (79 gal/min) Pressure 310 Bar (4 500 psi) Filter 5 microns | ELECTRICAL SYSTEM Voltage 24 V Battery Type Two AGM (Absorption Glass Mat) type. Battery Capacity 2 X 75 Ah Alternator Rating 28V 100A | | | | | | | | | | | | | | | | | | | | | | | | |
| | | STEERING SYSTEM Double acting cylinders, with ground-driven emergency steering pump. Lock to lock turns 4,5 Steering Angle 42° | MAX. VEHICLE SPEED <table border="1"> <tr><td>1st</td><td>4 km/h</td><td>2,5 mph</td></tr> <tr><td>2nd</td><td>9 km/h</td><td>6 mph</td></tr> <tr><td>3rd</td><td>17 km/h</td><td>11 mph</td></tr> <tr><td>4th</td><td>23 km/h</td><td>14 mph</td></tr> <tr><td>5th</td><td>33 km/h</td><td>21 mph</td></tr> <tr><td>6th</td><td>44 km/h</td><td>27,3 mph</td></tr> <tr><td>7th</td><td>51 km/h</td><td>32 mph</td></tr> <tr><td>R</td><td>7 km/h</td><td>4 mph</td></tr> </table> | 1st | 4 km/h | 2,5 mph | 2nd | 9 km/h | 6 mph | 3rd | 17 km/h | 11 mph | 4th | 23 km/h | 14 mph | 5th | 33 km/h | 21 mph | 6th | 44 km/h | 27,3 mph | 7th | 51 km/h | 32 mph | R | 7 km/h | 4 mph |
| 1st | 4 km/h | 2,5 mph | | | | | | | | | | | | | | | | | | | | | | | | | |
| 2nd | 9 km/h | 6 mph | | | | | | | | | | | | | | | | | | | | | | | | | |
| 3rd | 17 km/h | 11 mph | | | | | | | | | | | | | | | | | | | | | | | | | |
| 4th | 23 km/h | 14 mph | | | | | | | | | | | | | | | | | | | | | | | | | |
| 5th | 33 km/h | 21 mph | | | | | | | | | | | | | | | | | | | | | | | | | |
| 6th | 44 km/h | 27,3 mph | | | | | | | | | | | | | | | | | | | | | | | | | |
| 7th | 51 km/h | 32 mph | | | | | | | | | | | | | | | | | | | | | | | | | |
| R | 7 km/h | 4 mph | | | | | | | | | | | | | | | | | | | | | | | | | |
| | | | CAB ROPS/FOPS certified 77 dBA internal sound pressure measured according to ISO 6396. | | | | | | | | | | | | | | | | | | | | | | | | |

Load Capacity & Ground Pressure

| OPERATING WEIGHTS | | GROUND PRESSURE* | | | | LOAD CAPACITY | | OPTION WEIGHTS | |
|-------------------|------------------|---|--|------------|-----------------|--------------------------------|------------------|-----------------------|---------------|
| UNLADEN | kg (lb) | LADEN | | | | BODY | m³ (yd³) | kg (lb) | |
| Front | 17 614 (38 832) | No sinkage/Total Contact Area (as recommended by tyre manufacturer) | Calculation method used by competition | | Struck Capacity | 19,5 (25,5) | Bin liner | 1 404 (3 095) | |
| Middle | 9 177 (20 232) | | 29.5 R 25 | kPa (Psi) | 29.5 R 25 | kPa (Psi) | SAE 2:1 Capacity | 25 (33) | Tailgate |
| Rear | 8 688 (19 154) | Front | 314 (45,5) | Front | 153 (22,2) | SAE 1:1 Capacity | 29,5 (38) | Wheelset 875/65 R29 | |
| Total | 35 479 (78 217) | Mid/Rear | 370 (53,7) | Rear | 176 (25,5) | SAE 2:1 Capacity with Tailgate | 26 (34) | (per vehicle) Add | 1 338 (2 950) |
| LADEN | | | | | | | | EXTRA WHEELSET | |
| Front | 22 739 (50 131) | | | | | | | 29.5 R 25 | |
| Middle | 27 115 (59 778) | 875/65 R29 | | 875/65 R29 | | Rated Payload | 41 000 kg | (per vehicle) Add | 516 (1 138) |
| Rear | 26 626 (58 700) | Front | 295 (42,8) | Front | 135 (19,6) | | (90 390 lb) | 875/65 R29 | |
| Total | 76 479 (168 607) | Mid/Rear | 331 (48) | Rear | 154 (22,3) | | | (per vehicle) Add | 1 338 (2 950) |

* 29.5R25 Ground pressures calculated with Michelin XADN+ Tyre. 875/65R29 Groundpressures calculated with Michelin XAD65-1 Tyre.

Dimensions

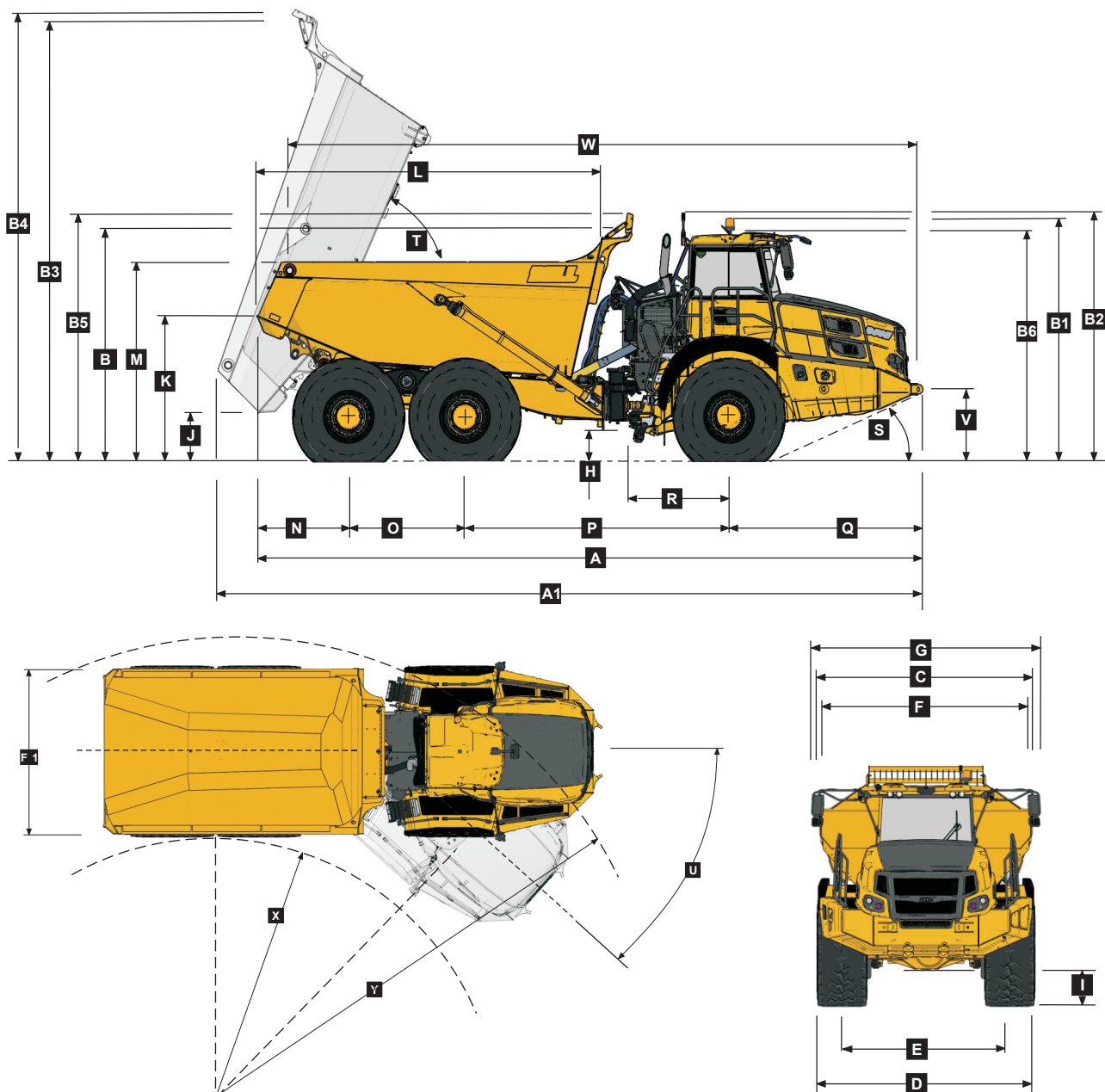

Machine Dimensions

| | | | | | | | |
|----|---|-----------|----------------|---|--|-----------|-----------------|
| A | Length - Transport Position with Tailgate | 11 184 mm | (36 ft. 8 in.) | I | Ground Clearance - Front Axle | 543 mm | (21.34 in.) |
| A | Length - Transport Position w/o Tailgate | 11 184 mm | (36 ft. 8 in.) | J | Ground Clearance - Bin Fully Tipped | 880 mm | (34.65 in.) |
| A1 | Length - Bin Fully Tipped | 11 778 mm | (38 ft. 8 in.) | K | Bin Lip Height - Transport Position | 2 521 mm | (8 ft. 3 in.) |
| B | Height - Transport Position w/o Rock Guard | 3 802 mm | (12 ft. 6 in.) | L | Bin Length | 5 753 mm | (18 ft. 10 in.) |
| B | Height - Transport Position with Rock Guard | 3 844 mm | (12 ft. 7 in.) | M | Load over Height | 3 316 mm | (10 ft. 11 in.) |
| B1 | Height - Rotating Beacon | 4 038 mm | (13 ft. 3 in.) | N | Rear Axle Centre to Bin Rear | 1 540 mm | (5 ft.) |
| B2 | Height - Load Light | 4 127 mm | (13 ft. 6 in.) | O | Mid Axle Centre to Rear Axle Centre | 1 950 mm | (6 ft. 5 in.) |
| B3 | Bin Height - Fully Tipped w/o Rock Guard | 7 340 mm | (24 ft. 1 in.) | P | Mid Axle Centre to Front Axle Centre | 4 438 mm | (14 ft. 7 in.) |
| B4 | Bin Height - Fully Tipped with Rock Guard | 7 448 mm | (24 ft. 5 in.) | Q | Front Axle Centre to Machine Front | 3 256 mm | (10 ft. 8 in.) |
| B5 | Height - Rock Guard Operating Position | 4 123 mm | (13 ft. 6 in.) | R | Front Axle Centre to Artic Centre | 1 558 mm | (5 ft. 1 in.) |
| B6 | Height - Cab | 3 802 mm | (12 ft. 6 in.) | S | Approach Angle | 24 ° | |
| C | Width over Mudguards | 3 495 mm | (11 ft. 6 in.) | T | Maximum Bin Tip Angle | 70 ° | |
| D | Width over Tyres - 875/65 R29 | 3 656 mm | (12 ft.) | U | Maximum Articulation Angle | 42 ° | |
| D | Width over Tyres - 29.5R25 | 3 487 mm | (11 ft. 5 in.) | V | Front Tie Down Height | 1 262 mm | (4 ft. 2 in.) |
| E | Tyre Track Width - 875/65 R29 | 2 773 mm | (9 ft. 1 in.) | W | Machine Lifting Centres | 10 569 mm | (34 ft. 8 in.) |
| E | Tyre Track Width - 29.5R25 | 2 725 mm | (8 ft. 11 in.) | X | Inner Turning Circle Radius - 875/65 R29 | 4 782 mm | (15 ft. 8 in.) |
| F | Width over Bin | 3 448 mm | (11 ft. 4 in.) | X | Inner Turning Circle Radius - 29.5R25 | 4 866 mm | (16 ft.) |
| F1 | Width over Tailgate | 3 738 mm | (12 ft. 3 in.) | Y | Outer Turning Circle Radius - 875/65 R29 | 9 320 mm | (30 ft. 7 in.) |
| G | Width over Mirrors - Operating Position | 4 027 mm | (13 ft. 3 in.) | Y | Outer Turning Circle Radius - 29.5R25 | 9 235 mm | (30 ft. 4 in.) |
| H | Ground Clearance - Artic | 545 mm | (21.46 in.) | | | | |

Gradeability/Rimpull

1. Determine tractive resistance by finding intersection of vehicle mass line and grade line. NOTE: 2% typical rolling resistance is already assumed in chart and grade line.
2. From this intersection, move straight right across charts until line intersects rimpull curve.
3. Read down from this point to determine maximum speed attained at that tractive resistance.

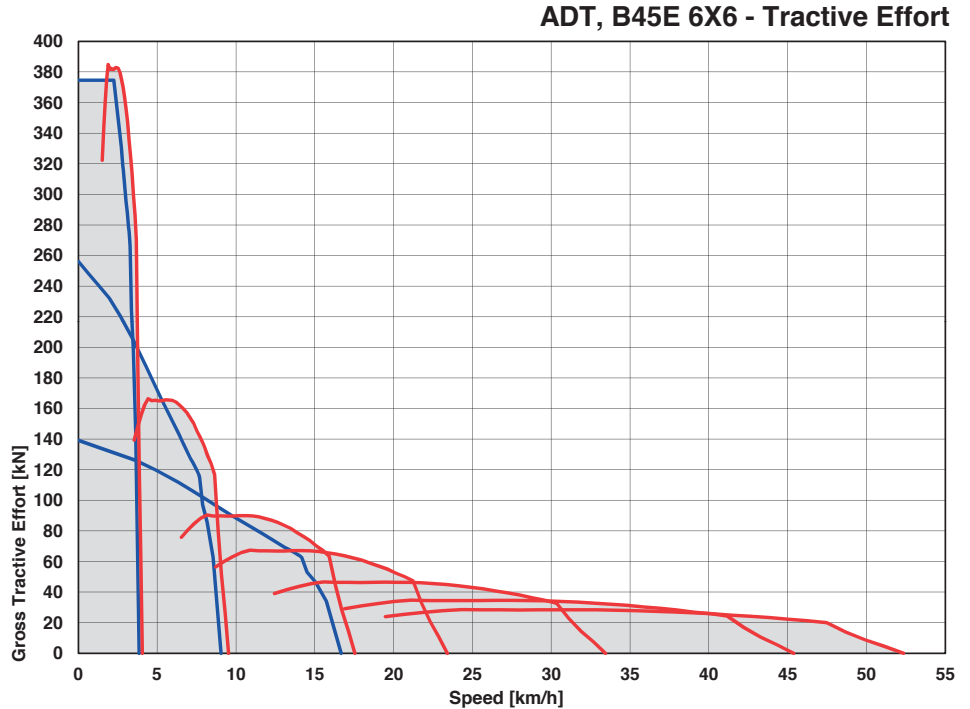
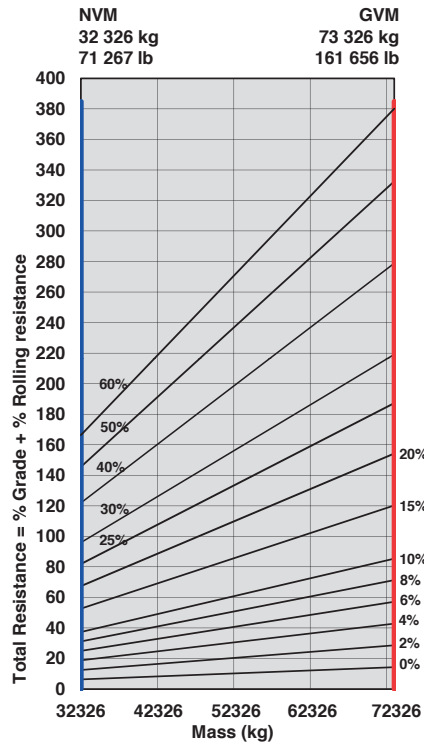

Retardation

1. Determine retardation force required by finding intersection of vehicle mass line.
2. From this intersection, move straight right across charts until line intersects the curve. NOTE: 2% typical rolling resistance is already assumed in chart.
3. Read down from this point to determine maximum speed.

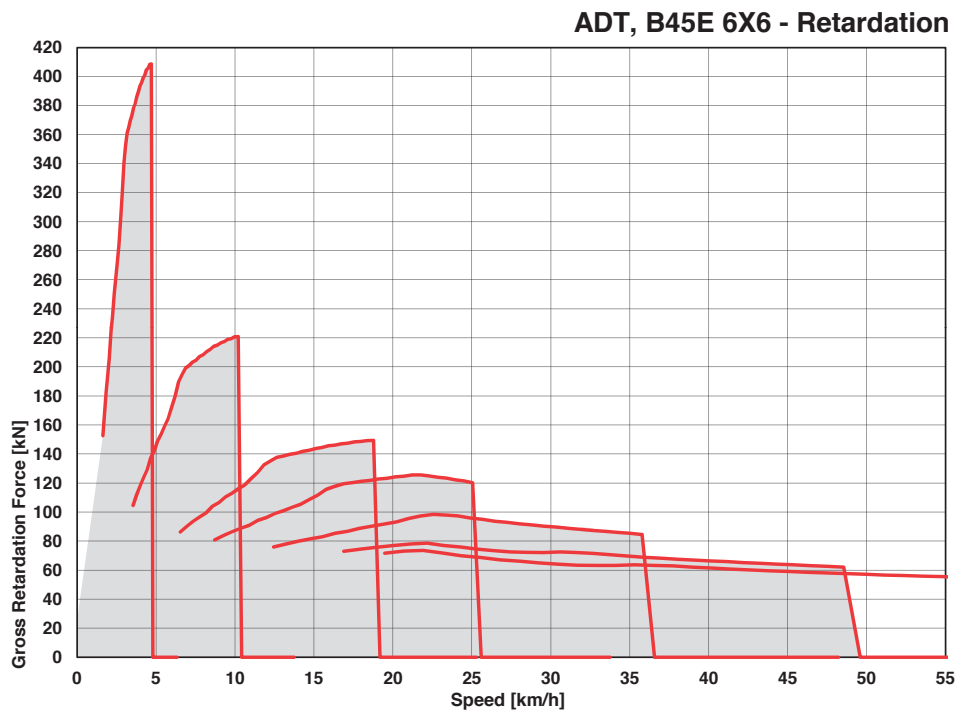
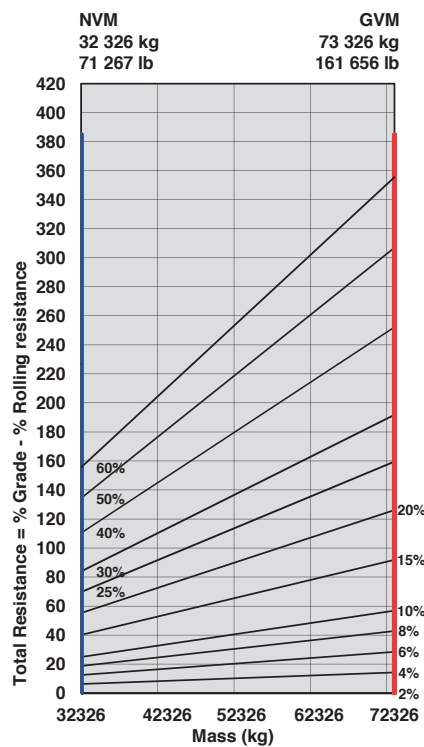

B50E Articulated Dump Truck

| | | | | | | | | | | | | | | | | | | | | | | | | | | | |
|--|--|--|--|-----|--------|---------|-----|--------|-------|-----|---------|--------|-----|---------|--------|-----|---------|--------|-----|---------|----------|-----|---------|--------|---|--------|-------|
| <p>ENGINE</p> <p>Manufacturer Mercedes Benz (MTU)</p> <p>Model OM473LA (MTU 6R 1500)</p> <p>Configuration Inline 6, turbocharged and intercooled.</p> <p>Maximum Net Power 430 kW (577 hp) at 1 600 rpm in accordance with UN ECE R120</p> <p>Gross Torque 2 850 Nm (2 102 lbf) @ 1 300 rpm</p> <p>Displacement 15,6 litres (952 cu.in)</p> <p>Auxiliary Brake Jacobs Engine Brake®</p> <p>Fuel Tank Capacity 494 litres (130 US gal)</p> <p>AdBlue® Tank Capacity 40 litres (11 US gal)</p> <p>Certification OM473LA (MTU 6R 1500) meets EU Stage V / EPA Tier 4 Final emissions regulations</p> | <p>TRANSFER CASE</p> <p>Manufacturer Kessler</p> <p>Series W2400</p> <p>Layout Remote mounted</p> <p>Gear Layout Three in-line helical gears</p> <p>Output Differential Interaxle 29/71 proportional differential. Automatic inter-axle differential lock.</p> | <p>WHEELS</p> <p>Type Radial Earthmover</p> <p>Tyre 875/65 R 29 (29.5 R 25 optional)</p> | <p>DUMPING SYSTEM</p> <p>Two double-acting, single stage, dump cylinders.</p> <p>Raise Time 12,5 seconds</p> <p>Lowering Time 11,5 seconds</p> <p>Tipping Angle 70 deg standard, or any lower angle programmable</p> | | | | | | | | | | | | | | | | | | | | | | | | |
| <p>TRANSMISSION</p> <p>Manufacturer Allison</p> <p>Model 4800 ORS</p> <p>Configuration Fully automatic planetary transmission.</p> <p>Layout Engine mounted</p> <p>Gear Layout Constant meshing planetary gears, clutch operated</p> <p>Gears 7 Forward, 1 Reverse</p> <p>Clutch Type Hydraulically operated multi-disc</p> <p>Control Type Electronic</p> <p>Torque Control Hydrodynamic with lock-up in all gears.</p> | <p>AXLES</p> <p>Manufacturer Bell</p> <p>Model 30T</p> <p>Differential High input controlled traction differential with spiral bevel gears</p> <p>Final Drive Outboard heavy duty planetary on all axles.</p> | <p>FRONT SUSPENSION</p> <p>Semi-independent, leading A-frame supported by hydro-pneumatic suspension struts. Active dual springrate Comfort Ride suspension, including height control.</p> <p>REAR SUSPENSION</p> <p>Pivoting walking beams with laminated rubber suspension blocks.</p> <p>Optional passive dual-springrate Comfort Ride walking beam available.</p> | <p>PNEUMATIC SYSTEM</p> <p>Air drier with heater and integral unloader valve, serving park brake and auxiliary functions.</p> <p>System Pressure 8,1 Bar (117 psi)</p> | | | | | | | | | | | | | | | | | | | | | | | | |
| | <p>BRAKING SYSTEM</p> <p>Service Brake Dual circuit, full hydraulic actuation wet disc brakes on front, middle and rear axles. Wet brake oil is circulated through a filtration and cooling system.</p> <p>Maximum brake force: 488 kN (109 707 lbf)</p> <p>Park & Emergency Spring applied, air released driveline mounted disc.</p> <p>Maximum brake force: 215,5 kN (48 446 lbf)</p> <p>Auxiliary Brake Jacobs Engine Brake®. Automatic retardation through electronic activation of wet brake system.</p> <p>Total Retardation Power Continuous: 546 kW (732 hp) Maximum: 963 kW (1 291 hp)</p> | <p>HYDRAULIC SYSTEM</p> <p>Full load sensing system serving the prioritized steering, body tipping, suspension and brake functions. A ground-driven, load sensing emergency steering pump is integrated into the main system.</p> <p>Pump Type Variable displacement load sensing piston</p> <p>Flow 300 L/min (79 gal/min)</p> <p>Pressure 310 Bar (4 500 psi)</p> <p>Filter 5 microns</p> | <p>ELECTRICAL SYSTEM</p> <p>Voltage 24 V</p> <p>Battery Type Two AGM (Absorption Glass Mat) type.</p> <p>Battery Capacity 2 X 75 Ah</p> <p>Alternator Rating 28V 100A</p> | | | | | | | | | | | | | | | | | | | | | | | | |
| | | <p>STEERING SYSTEM</p> <p>Double acting cylinders, with ground-driven emergency steering pump.</p> <p>Lock to lock turns 5,5</p> <p>Steering Angle 42°</p> | <p>MAX. VEHICLE SPEED</p> <table border="1"> <tr><td>1st</td><td>4 km/h</td><td>2,5 mph</td></tr> <tr><td>2nd</td><td>9 km/h</td><td>6 mph</td></tr> <tr><td>3rd</td><td>17 km/h</td><td>11 mph</td></tr> <tr><td>4th</td><td>23 km/h</td><td>14 mph</td></tr> <tr><td>5th</td><td>33 km/h</td><td>21 mph</td></tr> <tr><td>6th</td><td>44 km/h</td><td>27,3 mph</td></tr> <tr><td>7th</td><td>51 km/h</td><td>32 mph</td></tr> <tr><td>R</td><td>7 km/h</td><td>4 mph</td></tr> </table> | 1st | 4 km/h | 2,5 mph | 2nd | 9 km/h | 6 mph | 3rd | 17 km/h | 11 mph | 4th | 23 km/h | 14 mph | 5th | 33 km/h | 21 mph | 6th | 44 km/h | 27,3 mph | 7th | 51 km/h | 32 mph | R | 7 km/h | 4 mph |
| 1st | 4 km/h | 2,5 mph | | | | | | | | | | | | | | | | | | | | | | | | | |
| 2nd | 9 km/h | 6 mph | | | | | | | | | | | | | | | | | | | | | | | | | |
| 3rd | 17 km/h | 11 mph | | | | | | | | | | | | | | | | | | | | | | | | | |
| 4th | 23 km/h | 14 mph | | | | | | | | | | | | | | | | | | | | | | | | | |
| 5th | 33 km/h | 21 mph | | | | | | | | | | | | | | | | | | | | | | | | | |
| 6th | 44 km/h | 27,3 mph | | | | | | | | | | | | | | | | | | | | | | | | | |
| 7th | 51 km/h | 32 mph | | | | | | | | | | | | | | | | | | | | | | | | | |
| R | 7 km/h | 4 mph | | | | | | | | | | | | | | | | | | | | | | | | | |
| | | | <p>CAB</p> <p>ROPS/FOPS certified 77 dBA internal sound pressure measured according to ISO 6396.</p> | | | | | | | | | | | | | | | | | | | | | | | | |

Load Capacity & Ground Pressure

| OPERATING WEIGHTS | | GROUND PRESSURE* | | LOAD CAPACITY | | OPTION WEIGHTS | |
|-------------------|------------------|--|------------------|--------------------------------|-----------------------------------|-----------------------|---------------|
| UNLADEN | kg (lb) | LADEN | | BODY | m ³ (yd ³) | kg (lb) | |
| Front | 18 313 (40 373) | (No sinkage/Total Contact Area Method) | | Struck Capacity | 21,5 (28) | Bin liner | 1 495 (3 296) |
| Middle | 10 039 (22 132) | 875/65 R29 | kPa (Psi) | SAE 2:1 Capacity | 27,5 (36) | Tailgate | 1 136 (2 505) |
| Rear | 9 934 (21 901) | Front | 297 (43,1) | SAE 1:1 Capacity | 33 (43) | 29.5 R 25 | |
| Total | 38 287 (84 408) | Mid & Rear | 366 (53,1) | SAE 2:1 Capacity with Tailgate | 29 (38) | (per vehicle) Minus | 1 334 (2 941) |
| LADEN | | | | | | EXTRA WHEELSET | |
| Front | 24 034 (52 986) | 29.5 R 25 | kPa (Psi) | | | 29.5 R 25 | |
| Middle | 29 879 (65 872) | Front | 339 (49,2) | Rated Payload | 45 400 kg | (per vehicle) Add | 516 (1 138) |
| Rear | 29 774 (65 640) | Mid & Rear | 381 (55,3) | | (100 090 lb) | 875/65 R29 | |
| Total | 83 687 (184 498) | | | | | (per vehicle) Add | 1 338 (2 950) |

* 29.5R25 Ground pressures calculated with Michelin XADN+ Tyre. 875/65 R29 Groundpressures calculated with Michelin XAD65-1 Tyre.

B50E

Dimensions

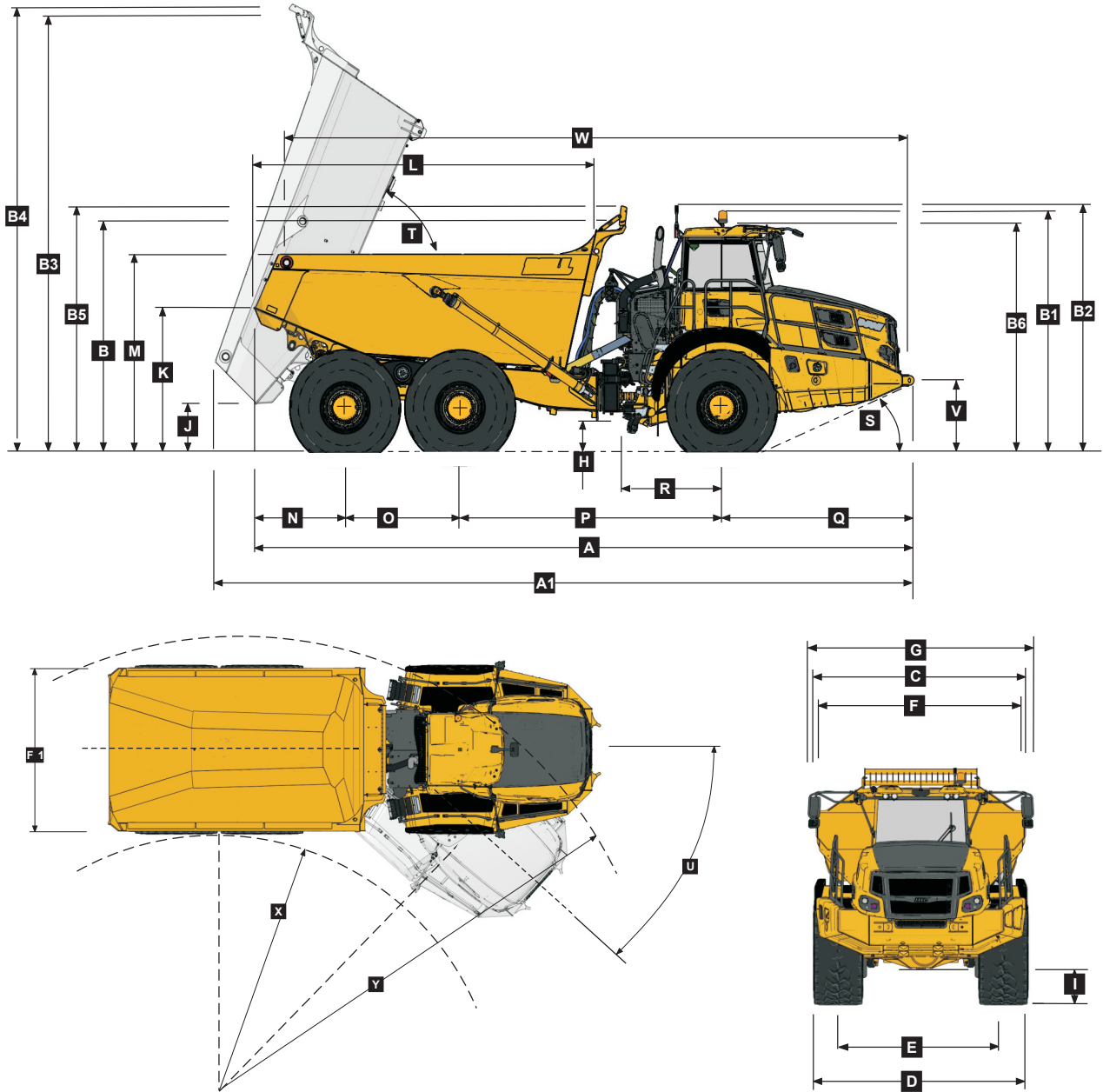

Machine Dimensions

| | | | | | | | |
|----|---|-----------|----------------|---|--|-----------|-----------------|
| A | Length - Transport Position with Tailgate | 11 272 mm | (37 ft.) | I | Ground Clearance - Front Axle | 555 mm | (21.85 in.) |
| A | Length - Transport Position w/o Tailgate | 11 272 mm | (37 ft.) | J | Ground Clearance - Bin Fully Tipped | 907 mm | (35.71 in.) |
| A1 | Length - Bin Fully Tipped | 11 916 mm | (39 ft. 1 in.) | K | Bin Lip Height - Transport Position | 2 542 mm | (8 ft. 4 in.) |
| B | Height - Transport Position w/o Rock Guard | 3 822 mm | (12 ft. 6 in.) | L | Bin Length | 5 714 mm | (18 ft. 9 in.) |
| B | Height - Transport Position with Rock Guard | 3 870 mm | (12 ft. 8 in.) | M | Load over Height | 3 390 mm | (11 ft. 1 in.) |
| B1 | Height - Rotating Beacon | 4 050 mm | (13 ft. 3 in.) | N | Rear Axle Centre to Bin Rear | 1 533 mm | (5 ft.) |
| B2 | Height - Load Light | 4 141 mm | (13 ft. 7 in.) | O | Mid Axle Centre to Rear Axle Centre | 1 950 mm | (6 ft. 5 in.) |
| B3 | Bin Height - Fully Tipped w/o Rock Guard | 7 325 mm | (24 ft.) | P | Mid Axle Centre to Front Axle Centre | 4 438 mm | (14 ft. 7 in.) |
| B4 | Bin Height - Fully Tipped with Rock Guard | 7 430 mm | (24 ft. 5 in.) | Q | Front Axle Centre to Machine Front | 3 351 mm | (11 ft.) |
| B5 | Height - Rock Guard Operating Position | 4 148 mm | (13 ft. 7 in.) | R | Front Axle Centre to Artic Centre | 1 558 mm | (5 ft. 1 in.) |
| B6 | Height - Cab | 3 813 mm | (12 ft. 6 in.) | S | Approach Angle | 23° | |
| C | Width over Mudguards | 3 790 mm | (12 ft. 5 in.) | T | Maximum Bin Tip Angle | 70° | |
| D | Width over Tyres - 875/65 R29 | 3 832 mm | (12 ft. 7 in.) | U | Maximum Articulation Angle | 42° | |
| D | Width over Tyres - 29.5R25 | 3 714 mm | (12 ft. 2 in.) | V | Front Tie Down Height | 1 269 mm | (4 ft. 2 in.) |
| E | Tyre Track Width - 875/65 R29 | 2 949 mm | (9 ft. 8 in.) | W | Machine Lifting Centres | 10 632 mm | (34 ft. 11 in.) |
| E | Tyre Track Width - 29.5R25 | 2 952 mm | (9 ft. 8 in.) | X | Inner Turning Circle Radius - 875/65 R29 | 4 694 mm | (15 ft. 5 in.) |
| F | Width over Bin | 3 735 mm | (12 ft. 3 in.) | X | Inner Turning Circle Radius - 29.5R25 | 4 753 mm | (15 ft. 7 in.) |
| F1 | Width over Tailgate | 4 057 mm | (13 ft. 4 in.) | Y | Outer Turning Circle Radius - 875/65 R29 | 9 408 mm | (30 ft. 10 in.) |
| G | Width over Mirrors - Operating Position | 4 027 mm | (13 ft. 3 in.) | Y | Outer Turning Circle Radius - 29.5R25 | 9 349 mm | (30 ft. 8 in.) |
| H | Ground Clearance - Artic | 558 mm | (21.97 in.) | | | | |

Gradeability/Rimpull

1. Determine tractive resistance by finding intersection of vehicle mass line and grade line. NOTE: 2% typical rolling resistance is already assumed in chart and grade line.
2. From this intersection, move straight right across charts until line intersects rimpull curve.
3. Read down from this point to determine maximum speed attained at that tractive resistance.

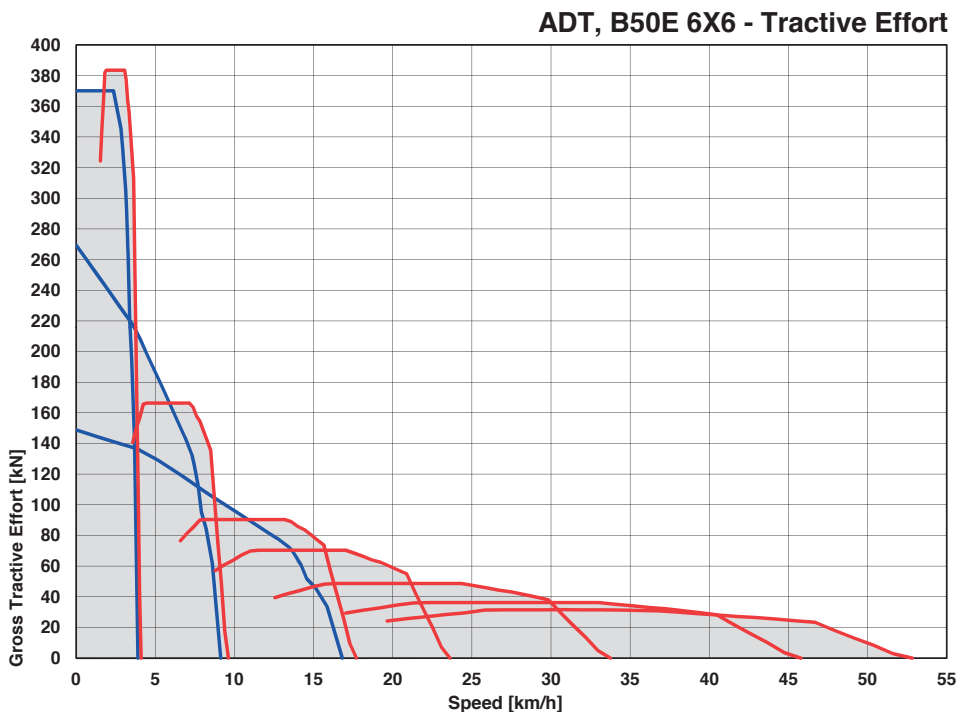
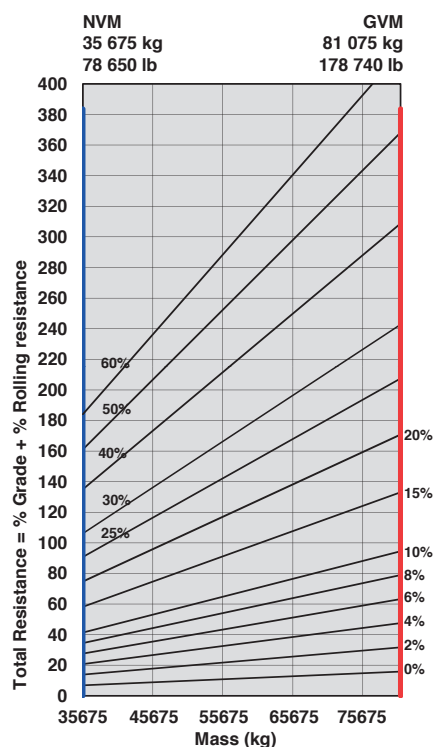

Retardation

1. Determine retardation force required by finding intersection of vehicle mass line.
2. From this intersection, move straight right across charts until line intersects the curve. NOTE: 2% typical rolling resistance is already assumed in chart.
3. Read down from this point to determine maximum speed.

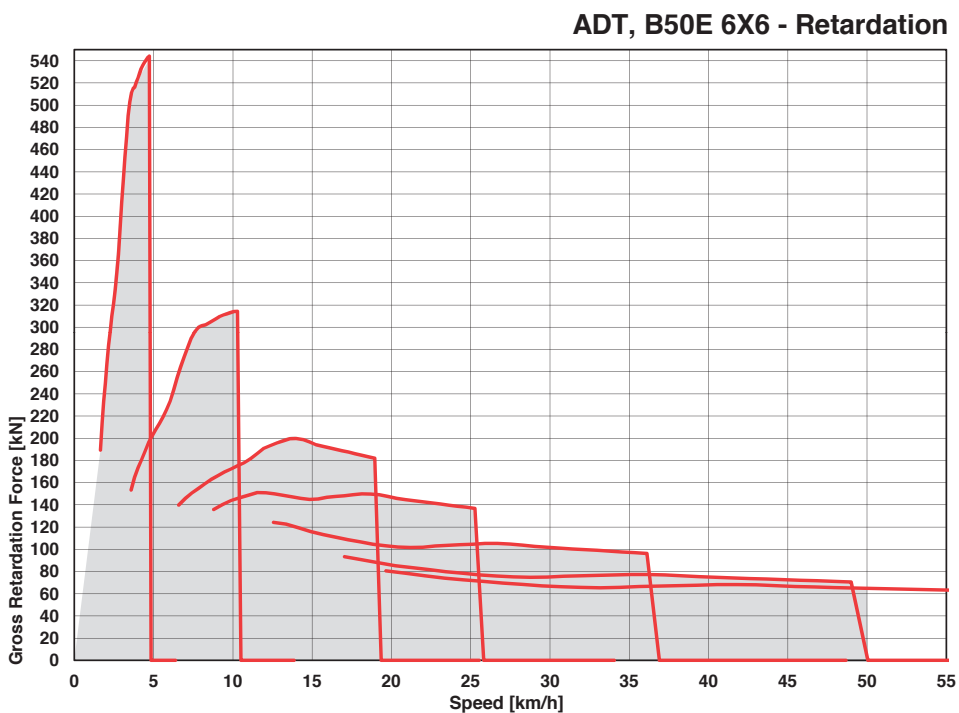
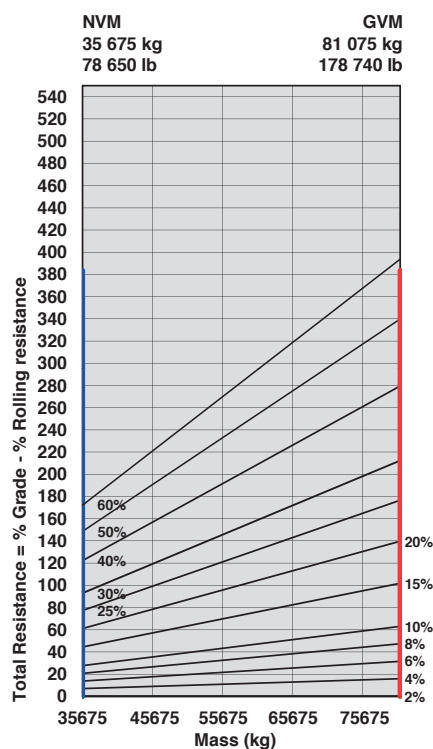

| B35E | B40E | B45E | B50E | | B35E | B40E | B45E | B50E | | | | |
|-------------------------------------|-------------------------------------|-------------------------------------|-------------------------------------|--|--------------------------|--------------------------|--------------------------|--------------------------|--|--------------------------|-------------------------------------|---|
| | | | | ENGINE | | | | | CAB (continued) | | | |
| <input type="checkbox"/> | <input type="checkbox"/> | <input type="checkbox"/> | <input type="checkbox"/> | Jacobs Engine Brake® | <input type="checkbox"/> | <input type="checkbox"/> | <input type="checkbox"/> | <input type="checkbox"/> | Manually adjusted mirrors | | | |
| <input type="checkbox"/> | <input type="checkbox"/> | <input type="checkbox"/> | <input type="checkbox"/> | Dual element air cleaner with dust ejector valve | <input type="checkbox"/> | <input type="checkbox"/> | <input type="checkbox"/> | <input type="checkbox"/> | Heated mirrors | | | |
| <input type="checkbox"/> | <input type="checkbox"/> | <input type="checkbox"/> | <input type="checkbox"/> | Precleaner with automatic dust scavenging | <input type="checkbox"/> | <input type="checkbox"/> | <input type="checkbox"/> | <input type="checkbox"/> | Electrically adjusted and heated mirrors | | | |
| <input type="checkbox"/> | <input type="checkbox"/> | <input type="checkbox"/> | <input type="checkbox"/> | Water separator | <input type="checkbox"/> | <input type="checkbox"/> | <input type="checkbox"/> | <input type="checkbox"/> | Deluxe 10" colour LCD: | | | |
| <input type="checkbox"/> | <input type="checkbox"/> | <input type="checkbox"/> | <input type="checkbox"/> | Serpentine drive belt with automatic tensioner | <input type="checkbox"/> | <input type="checkbox"/> | <input type="checkbox"/> | <input type="checkbox"/> | Speedometer / Fuel gauge / | | | |
| <input type="checkbox"/> | <input type="checkbox"/> | <input type="checkbox"/> | <input type="checkbox"/> | Provision for fast fill | <input type="checkbox"/> | <input type="checkbox"/> | <input type="checkbox"/> | <input type="checkbox"/> | Transmission oil temperature gauge / | | | |
| <input type="checkbox"/> | <input type="checkbox"/> | <input type="checkbox"/> | <input type="checkbox"/> | Wet-sleeve cylinder liners | <input type="checkbox"/> | <input type="checkbox"/> | <input type="checkbox"/> | <input type="checkbox"/> | Engine coolant temperature gauge / | | | |
| | | | | COOLING | | | | | DUMP BODY | | | |
| <input type="checkbox"/> | <input type="checkbox"/> | <input type="checkbox"/> | <input type="checkbox"/> | Crankshaft mounted electronically controlled viscous fan drive | <input type="checkbox"/> | <input type="checkbox"/> | <input type="checkbox"/> | <input type="checkbox"/> | Dump body mechanical locks (x2). Partially up and fully up | | | |
| <input type="checkbox"/> | <input type="checkbox"/> | <input type="checkbox"/> | <input type="checkbox"/> | Fan guard | <input type="checkbox"/> | <input type="checkbox"/> | <input type="checkbox"/> | <input type="checkbox"/> | Body liner | | | |
| | | | | PNEUMATIC SYSTEM | | | | | OTHER | | | |
| <input type="checkbox"/> | <input type="checkbox"/> | <input type="checkbox"/> | <input type="checkbox"/> | Engine-mounted compressor | <input type="checkbox"/> | <input type="checkbox"/> | <input type="checkbox"/> | <input type="checkbox"/> | Automatic Traction Control (ATC) | | | |
| <input type="checkbox"/> | <input type="checkbox"/> | <input type="checkbox"/> | <input type="checkbox"/> | Air drier with heater | <input type="checkbox"/> | <input type="checkbox"/> | <input type="checkbox"/> | <input type="checkbox"/> | Wet disc brakes | | | |
| <input type="checkbox"/> | <input type="checkbox"/> | <input type="checkbox"/> | <input type="checkbox"/> | Integral unloader valve | <input type="checkbox"/> | <input type="checkbox"/> | <input type="checkbox"/> | <input type="checkbox"/> | 26.5 R 25 Radial Earthmover tyres | | | |
| | | | | ELECTRICAL SYSTEM | | | | | <input type="checkbox"/> | <input type="checkbox"/> | <input type="checkbox"/> | 29.5 R 25 Radial Earthmover tyres |
| <input checked="" type="checkbox"/> | <input checked="" type="checkbox"/> | <input checked="" type="checkbox"/> | <input checked="" type="checkbox"/> | PDS Hardware | <input type="checkbox"/> | <input type="checkbox"/> | <input type="checkbox"/> | <input type="checkbox"/> | <input type="checkbox"/> | <input type="checkbox"/> | 875/65 R 29 Radial Earthmover tyres | |
| <input type="checkbox"/> | <input type="checkbox"/> | <input type="checkbox"/> | <input type="checkbox"/> | Battery disconnect | <input type="checkbox"/> | <input type="checkbox"/> | <input type="checkbox"/> | <input type="checkbox"/> | <input type="checkbox"/> | <input type="checkbox"/> | Remote grease banks | |
| <input type="checkbox"/> | <input type="checkbox"/> | <input type="checkbox"/> | <input type="checkbox"/> | Halogen drive lights | <input type="checkbox"/> | <input type="checkbox"/> | <input type="checkbox"/> | <input type="checkbox"/> | <input type="checkbox"/> | <input type="checkbox"/> | Automatic greasing | |
| <input checked="" type="checkbox"/> | <input checked="" type="checkbox"/> | <input checked="" type="checkbox"/> | <input checked="" type="checkbox"/> | LED drive lights | <input type="checkbox"/> | <input type="checkbox"/> | <input type="checkbox"/> | <input type="checkbox"/> | <input type="checkbox"/> | <input type="checkbox"/> | Onboard weighing | |
| <input type="checkbox"/> | <input type="checkbox"/> | <input type="checkbox"/> | <input type="checkbox"/> | Air horn | <input type="checkbox"/> | <input type="checkbox"/> | <input type="checkbox"/> | <input type="checkbox"/> | <input type="checkbox"/> | <input type="checkbox"/> | Load lights: stack | |
| <input type="checkbox"/> | <input type="checkbox"/> | <input type="checkbox"/> | <input type="checkbox"/> | Reverse alarm | <input type="checkbox"/> | <input type="checkbox"/> | <input type="checkbox"/> | <input type="checkbox"/> | <input type="checkbox"/> | <input type="checkbox"/> | Comfort ride suspension (Front) | |
| <input checked="" type="checkbox"/> | <input checked="" type="checkbox"/> | <input checked="" type="checkbox"/> | <input checked="" type="checkbox"/> | White noise reverse alarm | <input type="checkbox"/> | <input type="checkbox"/> | <input type="checkbox"/> | <input type="checkbox"/> | <input type="checkbox"/> | <input type="checkbox"/> | Comfort ride suspension (Rear) | |
| <input type="checkbox"/> | <input type="checkbox"/> | <input type="checkbox"/> | <input type="checkbox"/> | Rotating beacon | <input type="checkbox"/> | <input type="checkbox"/> | <input type="checkbox"/> | <input type="checkbox"/> | <input type="checkbox"/> | <input type="checkbox"/> | Reverse camera | |
| <input type="checkbox"/> | <input type="checkbox"/> | <input type="checkbox"/> | <input type="checkbox"/> | Pitch Roll Sensor | <input type="checkbox"/> | <input type="checkbox"/> | <input type="checkbox"/> | <input type="checkbox"/> | <input type="checkbox"/> | <input type="checkbox"/> | Hand rails | |
| <input type="checkbox"/> | <input type="checkbox"/> | <input type="checkbox"/> | <input type="checkbox"/> | Halogen Artic reverse light | <input type="checkbox"/> | <input type="checkbox"/> | <input type="checkbox"/> | <input type="checkbox"/> | <input type="checkbox"/> | <input type="checkbox"/> | HSE Hand rails | |
| <input checked="" type="checkbox"/> | <input checked="" type="checkbox"/> | <input checked="" type="checkbox"/> | <input checked="" type="checkbox"/> | LED Artic reverse light | <input type="checkbox"/> | <input type="checkbox"/> | <input type="checkbox"/> | <input type="checkbox"/> | <input type="checkbox"/> | <input type="checkbox"/> | Cab peak | |
| <input type="checkbox"/> | <input type="checkbox"/> | <input type="checkbox"/> | <input type="checkbox"/> | LED reverse lights | <input type="checkbox"/> | <input type="checkbox"/> | <input type="checkbox"/> | <input type="checkbox"/> | <input type="checkbox"/> | <input type="checkbox"/> | High pressure hydraulic filter | |
| | | | | STEERING SYSTEM | | | | | <input type="checkbox"/> | <input type="checkbox"/> | <input type="checkbox"/> | Fuel heater |
| <input type="checkbox"/> | <input type="checkbox"/> | <input type="checkbox"/> | <input type="checkbox"/> | Unidirectional pump | <input type="checkbox"/> | <input type="checkbox"/> | <input type="checkbox"/> | <input type="checkbox"/> | <input type="checkbox"/> | <input type="checkbox"/> | <input type="checkbox"/> | Belly plate |
| <input checked="" type="checkbox"/> | <input checked="" type="checkbox"/> | <input checked="" type="checkbox"/> | <input checked="" type="checkbox"/> | Bi-directional pump | <input type="checkbox"/> | <input type="checkbox"/> | <input type="checkbox"/> | <input type="checkbox"/> | <input type="checkbox"/> | <input type="checkbox"/> | <input type="checkbox"/> | Belly covers |
| | | | | CAB | | | | | <input type="checkbox"/> | <input type="checkbox"/> | <input type="checkbox"/> | Remote transmission filters |
| <input type="checkbox"/> | <input type="checkbox"/> | <input type="checkbox"/> | <input type="checkbox"/> | ROPS/FOPS certification | <input type="checkbox"/> | <input type="checkbox"/> | <input type="checkbox"/> | <input type="checkbox"/> | <input type="checkbox"/> | <input type="checkbox"/> | <input type="checkbox"/> | Engine and transmission remote drain-gravity |
| <input type="checkbox"/> | <input type="checkbox"/> | <input type="checkbox"/> | <input type="checkbox"/> | Tilt cab | <input type="checkbox"/> | <input type="checkbox"/> | <input type="checkbox"/> | <input type="checkbox"/> | <input type="checkbox"/> | <input type="checkbox"/> | <input type="checkbox"/> | Engine and transmission remote drain-scavenge |
| <input type="checkbox"/> | <input type="checkbox"/> | <input type="checkbox"/> | <input type="checkbox"/> | Gas strut-supported door | <input type="checkbox"/> | <input type="checkbox"/> | <input type="checkbox"/> | <input type="checkbox"/> | <input type="checkbox"/> | <input type="checkbox"/> | <input type="checkbox"/> | Window smash button |
| <input type="checkbox"/> | <input type="checkbox"/> | <input type="checkbox"/> | <input type="checkbox"/> | I-Tip programmable dump-body tip settings | <input type="checkbox"/> | <input type="checkbox"/> | <input type="checkbox"/> | <input type="checkbox"/> | <input type="checkbox"/> | <input type="checkbox"/> | <input type="checkbox"/> | High visibility mirrors |
| <input type="checkbox"/> | <input type="checkbox"/> | <input type="checkbox"/> | <input type="checkbox"/> | HVAC semi-climate control system | <input type="checkbox"/> | <input type="checkbox"/> | <input type="checkbox"/> | <input type="checkbox"/> | <input type="checkbox"/> | <input type="checkbox"/> | <input type="checkbox"/> | Fleetm@tic® Classic Package for 2 years |
| <input type="checkbox"/> | <input type="checkbox"/> | <input type="checkbox"/> | <input type="checkbox"/> | AM/FM radio with Aux + USB | <input type="checkbox"/> | <input type="checkbox"/> | <input type="checkbox"/> | <input type="checkbox"/> | <input type="checkbox"/> | <input type="checkbox"/> | <input type="checkbox"/> | Electronic bonnet opening |
| <input type="checkbox"/> | <input type="checkbox"/> | <input type="checkbox"/> | <input type="checkbox"/> | Rear window guard | <input type="checkbox"/> | <input type="checkbox"/> | <input type="checkbox"/> | <input type="checkbox"/> | <input type="checkbox"/> | <input type="checkbox"/> | <input type="checkbox"/> | |
| <input type="checkbox"/> | <input type="checkbox"/> | <input type="checkbox"/> | <input type="checkbox"/> | Wiper/washer with intermittent control | <input type="checkbox"/> | <input type="checkbox"/> | <input type="checkbox"/> | <input type="checkbox"/> | <input type="checkbox"/> | <input type="checkbox"/> | <input type="checkbox"/> | |
| <input type="checkbox"/> | <input type="checkbox"/> | <input type="checkbox"/> | <input type="checkbox"/> | Tilt and telescoping steering wheel | <input type="checkbox"/> | <input type="checkbox"/> | <input type="checkbox"/> | <input type="checkbox"/> | <input type="checkbox"/> | <input type="checkbox"/> | <input type="checkbox"/> | |
| <input type="checkbox"/> | <input type="checkbox"/> | <input type="checkbox"/> | <input type="checkbox"/> | Centre-mount air-suspension seat | <input type="checkbox"/> | <input type="checkbox"/> | <input type="checkbox"/> | <input type="checkbox"/> | <input type="checkbox"/> | <input type="checkbox"/> | <input type="checkbox"/> | |
| <input type="checkbox"/> | <input type="checkbox"/> | <input type="checkbox"/> | <input type="checkbox"/> | Halogen work lights | <input type="checkbox"/> | <input type="checkbox"/> | <input type="checkbox"/> | <input type="checkbox"/> | <input type="checkbox"/> | <input type="checkbox"/> | <input type="checkbox"/> | |
| <input checked="" type="checkbox"/> | <input checked="" type="checkbox"/> | <input checked="" type="checkbox"/> | <input checked="" type="checkbox"/> | LED work lights | <input type="checkbox"/> | <input type="checkbox"/> | <input type="checkbox"/> | <input type="checkbox"/> | <input type="checkbox"/> | <input type="checkbox"/> | <input type="checkbox"/> | |
| <input checked="" type="checkbox"/> | <input checked="" type="checkbox"/> | <input checked="" type="checkbox"/> | <input checked="" type="checkbox"/> | Rotating beacon: seat belt installation | <input type="checkbox"/> | <input type="checkbox"/> | <input type="checkbox"/> | <input type="checkbox"/> | <input type="checkbox"/> | <input type="checkbox"/> | <input type="checkbox"/> | |
| <input checked="" type="checkbox"/> | <input checked="" type="checkbox"/> | <input checked="" type="checkbox"/> | <input checked="" type="checkbox"/> | Remote engine and machine isolation | <input type="checkbox"/> | <input type="checkbox"/> | <input type="checkbox"/> | <input type="checkbox"/> | <input type="checkbox"/> | <input type="checkbox"/> | <input type="checkbox"/> | |
| <input type="checkbox"/> | <input type="checkbox"/> | <input type="checkbox"/> | <input type="checkbox"/> | Remote battery jump start | <input type="checkbox"/> | <input type="checkbox"/> | <input type="checkbox"/> | <input type="checkbox"/> | <input type="checkbox"/> | <input type="checkbox"/> | <input type="checkbox"/> | |
| <input type="checkbox"/> | <input type="checkbox"/> | <input type="checkbox"/> | <input type="checkbox"/> | Retractable 3 point seat belt | <input type="checkbox"/> | <input type="checkbox"/> | <input type="checkbox"/> | <input type="checkbox"/> | <input type="checkbox"/> | <input type="checkbox"/> | <input type="checkbox"/> | |
| <input type="checkbox"/> | <input type="checkbox"/> | <input type="checkbox"/> | <input type="checkbox"/> | Heated seat | <input type="checkbox"/> | <input type="checkbox"/> | <input type="checkbox"/> | <input type="checkbox"/> | <input type="checkbox"/> | <input type="checkbox"/> | <input type="checkbox"/> | |
| <input type="checkbox"/> | <input type="checkbox"/> | <input type="checkbox"/> | <input type="checkbox"/> | Foldaway trainer seat with retractable seat belt | <input type="checkbox"/> | <input type="checkbox"/> | <input type="checkbox"/> | <input type="checkbox"/> | <input type="checkbox"/> | <input type="checkbox"/> | <input type="checkbox"/> | |
| <input type="checkbox"/> | <input type="checkbox"/> | <input type="checkbox"/> | <input type="checkbox"/> | 12-volt power outlet | <input type="checkbox"/> | <input type="checkbox"/> | <input type="checkbox"/> | <input type="checkbox"/> | <input type="checkbox"/> | <input type="checkbox"/> | <input type="checkbox"/> | |
| <input type="checkbox"/> | <input type="checkbox"/> | <input type="checkbox"/> | <input type="checkbox"/> | Cab utility bin (removable) | <input type="checkbox"/> | <input type="checkbox"/> | <input type="checkbox"/> | <input type="checkbox"/> | <input type="checkbox"/> | <input type="checkbox"/> | <input type="checkbox"/> | |
| <input type="checkbox"/> | <input type="checkbox"/> | <input type="checkbox"/> | <input type="checkbox"/> | Cup holder | <input type="checkbox"/> | <input type="checkbox"/> | <input type="checkbox"/> | <input type="checkbox"/> | <input type="checkbox"/> | <input type="checkbox"/> | <input type="checkbox"/> | |
| <input type="checkbox"/> | <input type="checkbox"/> | <input type="checkbox"/> | <input type="checkbox"/> | Cooled/heated lunch box | <input type="checkbox"/> | <input type="checkbox"/> | <input type="checkbox"/> | <input type="checkbox"/> | <input type="checkbox"/> | <input type="checkbox"/> | <input type="checkbox"/> | |

The compilation of standard and optional equipment may vary by market region. Please check with your local distributor.



All dimensions are shown in millimetres, unless otherwise stated between brackets. Under our policy of continuous improvement, we reserve the right to change technical data and design without prior notice. Photographs featured in this brochure may include optional equipment. Blu@dVantage™ is a trademark of Bell Equipment Co. (PTY) Ltd AdBlue® is a registered trademark of VDA.

BELL INTERNATIONAL: Tel: +27 (0)35-907 9431

E-mail: marketing@bellequipment.com • www.bellequipment.com

 Tel: +61 (0)8-9355-2442

 Tel: +27 (0)11-928-9700

 Tel: +49 (0)6631 / 91-13-0

 Tel: +44 (0)1283-712862

 Tel: +33 (0)5-55-89-23-56

 Tel: +1 (854) 855 7507

• A636E30 • A640E30 • A645E30 • A650E30

**Strong Reliable Machines
Strong Reliable Support**

BELL