

ZW-7 series

HITACHI

Reliable solutions

# ZW310



## WHEEL LOADER

Model code : ZW310-7

Engine maximum power : 233 kW / 312 hp

Operating weight : 24 260 – 24 710 kg

Bucket capacity (heaped) : 3.2 – 4.5 m<sup>3</sup>

# You're in control

You're at the heart of Hitachi's design for its latest range of wheel loaders. To continuously improve on previous generation machines, we've focused on enhancing your experience in the cab as an operator.

We've considered the challenges you face as the owner of a successful business. And we've zoomed in on the ways in which we can support you over the life cycle of your machine.

By putting you at the heart of the ZW-7 range, we invite you to take control – over your workspace and your fleet. And by working in partnership, we will help you to create your vision.





# Inside



In control of your business

---

**8.** Improve your profit



In control of your comfort

---

**10.** Feel the difference



In control of your environment

---

**12.** Increase your safety



In control of your assets

---

**14.** Boost your uptime



In control of your fleet

---

**16.** Manage your machine



In control of your uptime

---

**18.** Protect your investment



In control of your performance

---

**20.** Customise your machine

# Complete control

The new ZW-7 range of wheel loaders puts you firmly in control, so you can feel assured of your machine's performance, and supported by the technological expertise and services that Hitachi provides.

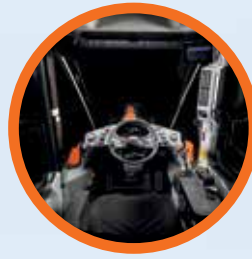

The cab interior provides a comfortable working environment.



Approach speed control maximises fuel efficiency on loading operations.



The payload checker helps you work more productively and accurately when loading trucks.



ConSite Pocket app allows you to manage and monitor your fleet remotely.



Options such as Hitachi ground engaging tools enable you to enhance the performance of your wheel loader.



Integrated console and seat suspension gives a greater sense of control and seat-mounted electric control levers reduce fatigue.



Visibility of the job site is excellent thanks to the Aerial Angle® camera system (optional) and new LCD monitor.



Safety is enhanced by the rear obstacle detection and warning system (optional).



The ECO gauge on the monitor indicates how to lower fuel consumption and reduce costs.



Maintenance is quick and easy due to improved access to components and anti-clogging radiators.



Higher engine output at lower engine RPM increases performance.



14

15

13

16

17

12

11

4

10

3

2

1

5

6

8

7

9

# Control zone

Enhanced comfort and safety features are at your fingertips in the refined cab of ZW-7 wheel loaders, giving you the power to perform productively, with ease and reduced fatigue.

- 1 **Seat-mounted electric control levers** help to reduce fatigue.
- 2 **Multifunction or finger-type control lever** options to suit your preference.
- 3 **Integrated console and seat suspension** gives a greater sense of control.
- 4 **USB power supply and smartphone holder** helps you stay connected.
- 5 **Armrest-Integrated sub monitor controller** provides fast access to main functions.
- 6 **Ergonomically designed adjustable armrest** so you can work comfortably.
- 7 **User-friendly storage space** keeps your workspace tidy and clutter-free.
- 8 **Heated heavy duty seat** with horizontal suspension.
- 9 **Drinks holder** is easy to detach for cleaning.
- 10 **Joystick Steering System** (optional) provides exceptional control.
- 11 **Anti-slip steering wheel** for effortless operation.
- 12 **3.5" colour liquid crystal display** in the front dashboard is easy to view.
- 13 **Spacious cab** gives you a pleasant working environment.
- 14 **Bluetooth®** for hands-free calls and DAB+ radio for music while you work. Audio is easily controlled.
- 15 **High-resolution 8" monitor** is easy to use and navigate.
- 16 **Panel switch integrated functions** are user-friendly.
- 17 **Electrically adjusted mirrors switch** is easy to use.



Operation is easy with ergonomically designed controls and switches.



All commonly used functions can be selected at a glance using the side panel switch.

In control of your business



# Improve your profit

The success of your business depends on the reliability and efficiency of your construction machinery. With Hitachi's latest ZW-7 wheel loaders, you can count on the highest quality, the ultimate in operating comfort and reduced running costs – all of which will have a positive impact on your bottom line.

You can look forward to increasing your profits thanks to the powerful performance, low total cost of ownership and exceptional efficiency of the Stage-V compliant ZW310-7. It delivers high levels of productivity due to fast cycle times, a high breakout force and loading capacity, and improved acceleration on inclines, thanks to a number of sensors installed on several machine components.

Short loading operations are completed faster and more efficiently using the approach speed control feature, which reduces fuel consumption. To enhance productivity and save fuel with reduced cycle times, operators will benefit from the auto power up function, which automatically increases the RPM to maintain the same travel speed when going uphill.

Another way for your operators to control fuel efficiency – and reduce costs – is by using the all-new ECO gauge. They can also improve performance with several adjustable functions to suit the material and job site conditions.

Your operators can also work more productively and accurately thanks to the payload checker. This enables them to keep track of load weights in real time on the monitor and find out how much material is in the bucket or truck. The display shows when the bucket or truck is overloaded, so you can adjust the final load to achieve target capacity.



Work more productively and accurately using the payload checker.





The ECO gauge helps to deliver better fuel consumption.



Approach speed control maximises efficiency.



You're in control with a spacious, tidy and enjoyable working environment.



The cab has ample space for your belongings.



The LCD monitor is easy to view with hi-res screen.



In control of your comfort



# Feel the difference

Hitachi's redesigned, state-of-the-art ZW-7 cab gives you the perfect working environment. The ultra-spacious ZW310-7 offers you an industry-leading, first-class cab with the ultimate in comfort and quality, as well as some of the lowest noise and vibration levels in the market.

Feel the difference with the synchronised motion of the seat and console, and seat-mounted electric control levers, which have been designed to ensure you feel less tired at the end of the working day.

Easy operation comes with the ergonomic design of the multifunction lever, the anti-slip steering wheel and the 40% larger fully adjustable armrest with integrated controller. You can navigate quickly through the menu on the 8" LCD monitor with the multifunctional controller. The hi-res screen is also easier to view, and the refreshed layout offers a clear display and desirable functionality.

With more storage for your personal belongings, such as your coat, smartphone and drink, you'll feel instantly relaxed and ready for your shift. Practical functions of the control levers, such as the quick power switch and horn, will make your working day effortless.



Ergonomic multifunctional control panel provides easy access.

In control of your environment



# Increase your safety

Your ability to work safely is vital, not only for your own wellbeing, but also for the successful completion of any project. To protect yourself and your machine from potential hazards, the new Hitachi ZW-7 wheel loaders give you a superior view of your surroundings, so you can see the job site from all angles.

The visibility you enjoy from the cab includes an exceptional 270-degree bird's-eye view with the Aerial Angle® camera system. You can choose from two image options to view the machine's immediate environment, which enables you to control your own safety – as well as that of those around you.

The rear obstacle detection and warning system also enhances safety on the job site, with real-time speed, machine position status and large detection zone.

To help you to work more confidently and efficiently, even in the most challenging of conditions, ZW-7 wheel loaders are fitted with some impressive new features. From the LED work lights (in two variants: standard 1200lm and high brightness 4200lm) and roller sunshades, you'll have the visibility you need when it matters most.



Electrically adjusted mirrors provide a clear rear view.

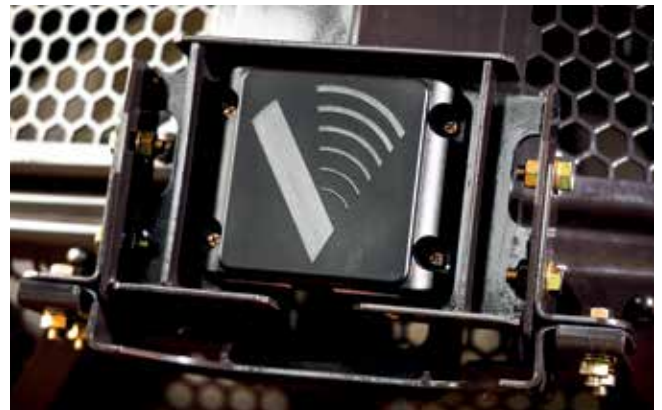

Rear obstacle detection system enhances safety on the job site.



Control your safety with the 270-degree view Aerial Angle® camera system.



Choose between different image layouts to suit your working environment.



LED work lights improve visibility in challenging conditions.



Daily inspection reminders make life easier for operators.



Easy maintenance features minimise downtime.



Intelligent fan operation system prevents radiators clogging.



Engine cover enables convenient access for daily inspections.



Hitachi wheel loaders are tested rigorously to ensure high levels of durability.



In control of your assets



# Boost your uptime

Completing a project on time and on budget depends on the ability of your construction equipment to perform all day, every day. That's why Hitachi owners have profited from generations of ultra-reliable and durable machinery – and the ZW-7 range is no exception.

The latest Hitachi wheel loaders have been built to last, so that you can remain in complete control of your assets. They have been tested rigorously and continuously at dedicated facilities in Japan with the goal of significantly boosting your uptime.

As a result, several unique durability-enhancing components have been fitted to the ZW310-7, including the axles and frame. The intelligent fan operation system prevents radiators from clogging by adjusting the periodic intervals of the automatic reversible fan electronically.

Downtime is minimised by the priority given to easy maintenance features, such as the improved cooling package and anti-clogging radiators as standard, which save you time and money.

## In control of your fleet



# Manage your machine

Hitachi offers a wide range of after-sales services to help you feel in total control of your fleet and workload. These initiatives give you access to vital data and tools to manage your machine.

Remote monitoring systems Owner's Site and ConSite send operational data daily via GPRS or satellite from your wheel loader to [www.globaleservice.com](http://www.globaleservice.com). This includes: ratios of operating hours to enhance efficiency; fuel consumption to manage running costs; and machine location for planning purposes. ConSite summarises the information in a monthly email.

The ConSite Pocket App sends you real-time alerts for issues arising with your machine. You'll receive recommendations on what to do and step-by-step help guides. The app also enables you to see the location of your fleet.



The alerts on the ConSite Pocket App provide real-time information.



A wide range of data on Global e-Service enhances efficiency.



Monitoring the performance of your wheel loader ensures exceptional reliability.





Hitachi offers a wide range of after-sales services for planning maintenance and managing running costs.



Hitachi provides the highest level of technical support.



Minimise downtime with Hitachi Genuine Parts.



HELP extended warranties and service contracts provide optimal performance.



Hitachi Premium Rental enables you to pay as you earn.



In control of your uptime



# Protect your investment

We apply the same technological expertise to our wide range of high-quality parts as we do our machines. As a result, you can minimise unscheduled downtime and ensure maximum availability.

The parts range includes Hitachi Genuine Parts, Performance Parts and filters. We also offer robust ground engaging tools and high-quality buckets, which have been manufactured to the same exacting standards.

As your business grows, you may need to extend your fleet to meet the demands of new contracts. Why not try before you buy with the Hitachi Premium Rental programme? This gives you immediate access to ZW-7 wheel loaders and Zaxis-7 excavators for a period of one month to a year.

Along with the reliability, quality and service you would expect from the Hitachi brand, Hitachi Premium Rental offers flexible contracts and fixed costs that make it easier for you to budget.



# Customise your machine

Designed to work in perfect harmony with your wheel loader, Hitachi's durable buckets and robust ground engaging tools (GET) will increase your profit by maximising productivity and uptime. Manufactured to the same high standards as all Hitachi construction equipment, they offer unrivalled reliability, exceptional performance and peace of mind that you are getting the most from your Hitachi machine.

## The right bucket for the job

You can increase the versatility of your wheel loader by choosing the right bucket for the job. For loading light materials or heavy-duty work, Hitachi buckets can be customised to meet your needs. You have a wide range of options to choose from – including general purpose, rock, high dump and light material buckets – and selectable options such as types of floors and spill guards, side cutter shapes, side wear plates and wear parts are also available. The ISO quick coupling system makes it easy for you to quickly connect Hitachi buckets to your wheel loader.

## Enhanced digging power

You can enhance the digging power and productivity of your wheel loader with Hitachi GET. Quick and safe to install and replace, they fit precisely to your attachments and can be tailored to suit the task. Using Hitachi GET can reduce your maintenance costs and downtime, lower fuel consumption and enhance the overall performance of your machine.



Straight side cutter



Convex side cutter

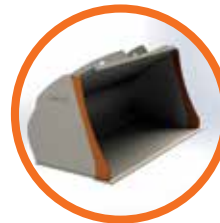

Concave side cutter



Spade edge



Straight edge





Spill guard tube style



Spill guard hood style



Standard spill guard



Spill guard with vision slots



Enlarged spill guard



Teeth

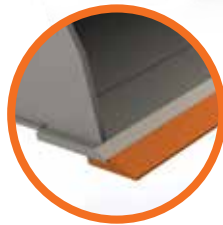

Profiled cutting edge



Flat floor



Teeth segments

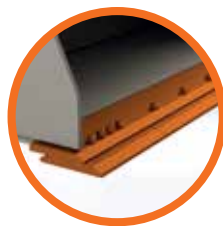

Cutting edge



Round floor



EH dump trucks and EX ultra-large excavators



Special application excavators



Create your vision

---

# In control of your world

With extensive expertise in designing and manufacturing wheel loaders, as well as a 50-year heritage in producing hydraulic excavators and a reputation as the industry's leading mining machine manufacturer, the Hitachi network will give you access to a range of exceptional construction equipment.

Like the new ZW-7 wheel loaders, Hitachi excavators, rigid dump trucks, and special application machines incorporate advanced technology and pioneering expertise.

In addition to the latest products made at state-of-the-art facilities and built to the highest quality standards, you'll have the support of our experienced engineers and dedicated dealer personnel. You'll also benefit from market-leading services and initiatives, such as Premium Rental and Premium Used, which have been created to enhance your experience as a Hitachi customer.

Whatever vision you wish to create, Hitachi has the product, people, solutions and services you need to make it become a reality – and empower you to take control of your world.



Zaxis medium excavators



Zaxis mini excavators

# SPECIFICATIONS

## ENGINE

Model .....	CUMMINS L9
Type .....	4-cycle water-cooled, direct injection
Aspiration .....	Waste-gate turbocharger and intercooled
Aftertreatment .....	DPF and SCR system
No. of cylinders .....	6
Maximum power	
ECE R120, gross .....	233 kW (312 hp) at 1 700 min <sup>-1</sup> (rpm)
ISO9249: 2007, net .....	226 kW (303 hp) at 1 700 min <sup>-1</sup> (rpm)
Rated power	
ISO14396: 2002, gross ....	213 kW (286 hp) at 2 000 min <sup>-1</sup> (rpm)
ISO9249: 2007, net .....	204 kW (274 hp) at 2 000 min <sup>-1</sup> (rpm)
Maximum torque, gross ....	1 636 Nm at 1 100 min <sup>-1</sup> (rpm)
Bore and stroke .....	137 mm X 146 mm
Piston displacement .....	8.9 L
Batteries .....	2 x 12 V
Air cleaner .....	Two element dry type with restriction indicator

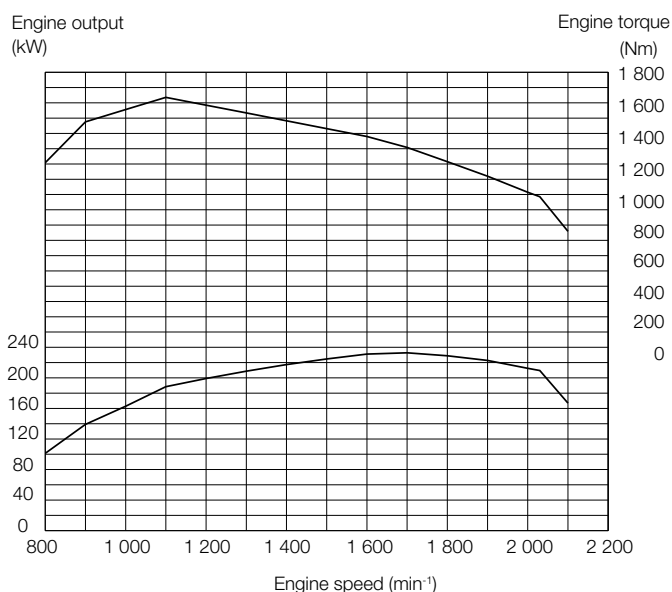

## POWER TRAIN

Transmission .....	Torque converter, countershaft type powershift with computer-controlled automatic shift and manual shift features included
Torque converter .....	Three element, single stage, single phase with lock-up clutch
Main clutch .....	Wet hydraulic, multi-disc type
Cooling method .....	Forced circulation type
Travel speed* Forward / Reverse	
1st .....	6.7 [6.7] {6.9} / 6.0 [6.7] {6.9} km/h
2nd .....	11.4 (11.5) [11.4 (11.5)] {11.9 (11.9)} / 10.3 (10.4) [11.4 (11.5)] {11.9 (11.9)} km/h
3rd .....	22.1 (22.5) [22.1 (22.5)] {22.1 (22.5)} / 22.1 (22.5) [22.1 (22.5)] {22.1 (22.5)} km/h
4th .....	36.0 (36.0) [36.0 (36.0)] {36.0 (36.0)} / 36.0 (36.0) [36.0 (36.0)] {36.0 (36.0)} km/h

\*With 26.5R25(L3) tires

( ) : Data at Lock-up clutch ON

[ ] : Data at Power Mode

{ } : Data at Power+ Mode

## AXLE AND FINAL DRIVE

Drive system .....	Four-wheel drive system
Front & rear axle .....	Semi-floating
Front .....	Fixed to the front frame
Rear .....	Trunnion support
Reduction and differential gear .....	Two stage reduction with torque proportioning differential
Oscillation angle .....	Total 24° (+12°, -12°)
Final drives .....	Heavy-duty planetary, mounted inboard

## TIRES

Tire size .....	26.5R25(L3)XHA2
Optional .....	Refer to standard & optional equipment list

## BRAKES

Service brakes .....	Inboard mounted fully hydraulic 4 wheel wet disc brake. Front & rear independent brake circuit
Parking brakes .....	Spring applied, hydraulically released, located in transmission.

## STEERING SYSTEM

Type .....	Articulated frame steering
Steering angle .....	Each direction 37° ; total 74°
Cylinders .....	Double-acting piston type
No. x Bore x Stroke .....	2 x 85 mm x 498 mm

## HYDRAULIC SYSTEM

Arm and bucket are controlled by multifunction lever	
Arm controls .....	Four position valve; Raise, hold, lower, float
Bucket controls with automatic bucket return-to-dig control .....	Three position valve ; Roll back, hold, dump
Main pump (Serve as steering pump) .....	Variable piston type
Maximum flow .....	300 L/min at 2 000 min <sup>-1</sup> (rpm)
Maximum pressure ..	31.4 MPa
Fan pump .....	Gear type
Maximum flow .....	85 L/min at 2 000 min <sup>-1</sup> (rpm)
Maximum pressure ..	16.5 MPa
Hydraulic cylinders	
Type .....	Double acting type
No. x Bore x Stroke ...	Arm : 2 x 145 mm x 884 mm Bucket : 1 x 180 mm x 525 mm
Filters .....	Full-flow 15 micron return filter in reservoir
Hydraulic cycle times	
Lift arm raise .....	5.6 s (5.5 s)
Lift arm lower .....	4.1 s (4.1 s)
Bucket dump .....	1.2 s (1.2 s)
Total .....	10.9 s (10.8 s)

\*Data at Power+ Mode

## ENVIRONMENT

### Engine Emissions

EU Stage V

### Sound level

Sound level in cab according to ISO 6396: 2008 ..... LpA 69 dB(A)

External sound level according to ISO 6395: 2008 and

EU Directive 2000/14/EC ..... LwA 107 dB(A)

### Air Conditioning System

The air conditioning system contains fluorinated greenhouse gases.

Refrigerant type: HFC-134a, GWP: 1430, Amount: 0.75 kg, CO<sub>2</sub>e: 1.07 ton.

## SERVICE REFILL CAPACITIES

Fuel tank .....	379 L
Engine coolant .....	37 L
Engine oil .....	33 L
Torque converter & transmission .....	51 L
Front axle differential & wheel hubs .....	48 L
Rear axle differential & wheel hubs .....	48 L
Hydraulic oil tank .....	139 L
DEF/AdBlue® tank .....	48 L



## DIMENSIONS & SPECIFICATIONS

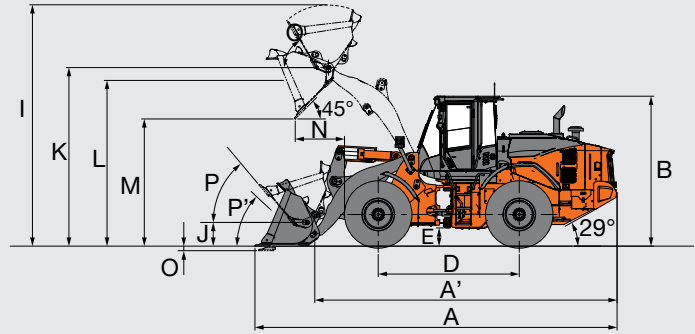
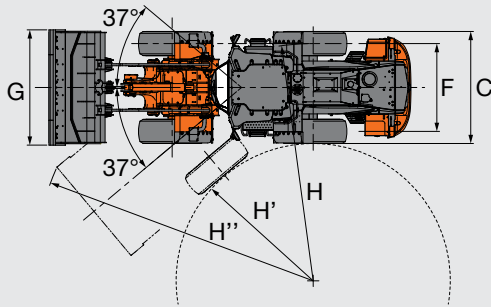

Bucket type		Standard arm						High lift arm	
		General purpose					Rock bucket	Light material	
		Round bottom		Flat bottom				Round bottom	
		Bolt-on cutting edge	Weld-on adapter & teeth	Bolt-on cutting edge	Bolt-on cutting edge	Weld-on adapter & teeth	Weld-on adapter & teeth	Bolt-on cutting edge	
Bucket capacity	ISO 7546: 1983 Heaped	m <sup>3</sup>	4.3	4.1	4.3	4.5	4.1	3.2	4.3
Bucket capacity	ISO 7546: 1983 Struck	m <sup>3</sup>	3.7	3.5	3.7	3.9	3.5	2.7	3.7
A Overall length		mm	9 015	9 175	9 015	9 065	9 175	9 090	9 465
A' Overall length (without bucket)		mm	7 450						7 900
B Overall height	up to cab top	mm							3 530
C Width over tires	outside tire	mm							2 930
D Wheel base		mm							3 540
E Ground clearance	Minimum	mm							500
F Tread		mm							2 230
G Bucket width		mm							2 980
H Turning radius (Centerline of outside tire)		mm							6 420
H' Turning radius to inside of tires		mm							3 870
H'' Loader clearance radius, bucket in carry position		mm	7 385	7 420	7 385	7 400	7 420	7 365	7 615
I Overall operating height	bucket full raise	mm	6 020		6 050		6 020	5 745	6 435
J Carry height of bucket pin	at carry position	mm							435
K Height to bucket hinge pin, fully raised		mm							4 425
L Lift arm clearance at max lift		mm							3 870
M Dumping clearance 45 degree, full height		mm	3 090	2 995	3 090	3 060	2 995	3 055	3 530
N Reach, 45 degree dump, full height		mm	1 305	1 440	1 305	1 355	1 440	1 380	1 370
O Digging depth (Horizontal digging angle)		mm	120	95	120	115	95	95	120
P Max. roll back at carry position		deg							45
P' Max. roll back at ground level		deg							41
Q Roll back angle at full height		deg							61
Static tipping load ISO 14397-1: 2007(Section 1-5) *	Straight	kg	18 830	19 160	18 700	18 650	19 040	18 670	15 720
	Full 37 degree turn	kg	16 040	16 320	15 930	15 880	16 220	15 900	13400
Breakout force		kN	189	203	189	183	203	223	190
		kgf	19 290	20 710	19 290	18 670	20 710	22 760	19 390
Operating weight *		kg	24 390	24 260	24 520	24 520	24 380	24 380	24 710
Articulate angle		deg							37
Departure angle		deg							30
Operating load		kg							7 140
									5 880

\*: Static tipping load and operating weight marked with\* include 26.5R25(L3) tires (No ballast) with lubricants, full fuel tank and operator. Machine stability and operating weight depend on counterweight, tire size and other attachments.

## WEIGHT CHANGE

Option item	Operating weight (kg)	Tipping load (kg)		Overall width (mm) (outside tire)	Overall height (mm)	Overall length (mm)
		Straight	Full turn			
Tire	26.5R25(L3) XHA2	± 0	± 0	± 0	± 0	± 0
	26.5R25(L5) XLDD2A	+660	+500	+440	+15	+35
	26.5R25(L5) XMINED2 PRO	+ 1 190	+870	+760	+45	+60
Belly guard		+240	+140	+130	± 0	± 0

## BUCKET SELECTION GUIDE

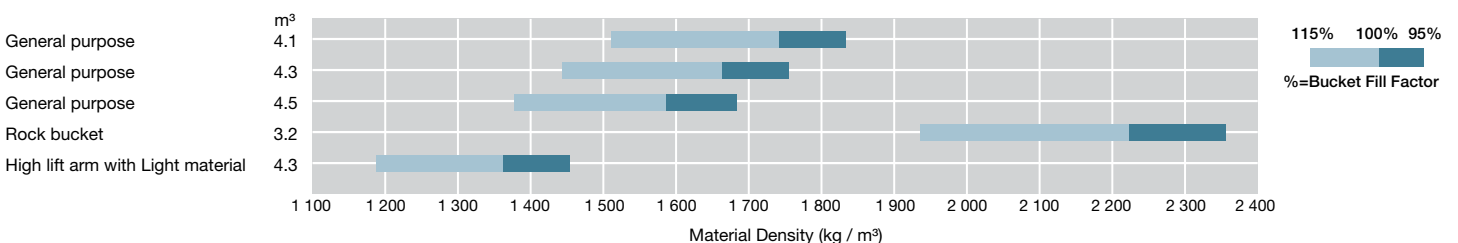

# EQUIPMENT

● ..... Standard equipment

○ ..... Optional equipment

## ENGINE

Aftertreatment device	●
Aftertreatment manual regeneration inhibit switch	●
Aftertreatment manual regeneration switch	●
Air filter double elements	●
Air intake	
Pre-cleaner (Sy-Klone)	●
Pre-cleaner (Turbo II)	○
Anti-clogging radiator (Wide fin pitch radiator)	●
Automatic reversible cooling fan with heat sensing	●
Cartridge-type engine oil filter	●
Cartridge-type fuel main filter	●
Cartridge-type fuel pre-filter	●
Coolant reservoir sight gauge	●
DEF/AdBlue® tank extension filler	●
DEF/AdBlue® tank with ISO magnet adapter	●
Engine auto shut-down control system	●
Engine oil remote drain	●
Fan guard	●

## BRAKE SYSTEM

Front and rear independent brake circuit	●
Inboard mounted fully hydraulic 4 wheel wet disc	●
Spring-applied/Hydraulic-released parking brake	●

## HYDRAULIC SYSTEM

Bucket auto leveler (Automatic return to dig control)	●
Control lever	
for 2 spools control valve	
MF lever	○
2 levers	●
for 3rd spools control valve	
MF lever & AUX lever for 3rd function	○
2 levers & AUX lever for 3rd function	○
- Inside layout pattern (3rd - bucket - liftarm)	○
Control lever lock switch	●
Dual lift arm auto leveler	●
Hydraulic filters	●
Lift arm float system	●
Reservoir sight gauge	●
Ride control system (OFF-AUTO type)	●
Work mode selector	●

## CAB

Adjustable steering column with POP-UP	●
Auto control air conditioner	
with double intake filter	●
Pre-cleaner for air conditioner	○
Bluetooth® integrated DAB+radio, hands-free calling	●
Camera & monitor	
Aerial Angle® (Side and rear view camera)	○
Rear view camera & monitor	●
Coat hook	●
Evacuation hammer	●
Front/Rear defroster	●
Glove compartment	●
LED room light	●
Payload checker with tip-off function	●
Rear obstacle detection system	○
Rear view mirrors	
Rear view mirrors	●
Outside (Heated, 2) electrical adjustment retractable mirror stay	●
ROPS (ISO3471: 2008), FOPS (ISO3449: 2008 LEVEL II): multi-plane isolation mounted for noise	●
Rubber floor mat	●
Seat	
Heavy duty air suspension seat equipped with horizontal suspension headrest and heater: fabric, high back, adjustable for damper, inclination of the seat, seat depth, weight-height, fore-aft position, reclining angle, armrest angle, headrest height and angle, lumbar support	●
Seat belt reminder	●
Steering system	
Joystick steering (with wheel steering)	○
Wheel steering	●
Storage	
Cup holder	●
Document holder	●
Hot & cool box	●
Seatback pocket	●
Smartphone and Tablet device holder	●
Sun shade film on front windshield	○
Sunscreen roller type	●
Tinted safety glass	
Front windshield: laminated	●
Others: tempered	●
USB power supply	●
Windshield washer front and rear	●
2 speakers	●
8 inch sub monitor	●

## MONITORING SYSTEM

Gauge: coolant temperature, fuel level, transmission oil temperature	●
Indicator lights : clearance lights, control lever lock, fuel level, high beam, parking brake, preheat, turn signals, work lights, fan reverse indicator, seat belt indicator	
Indicator on multifunction monitor: F-N-R shift position, gear shift position, clock, DEF alarm indicator, DEF level gauge, ECO indicator, forward/reverse selector switch indicator, hold display, hour meter, joystick steering indicator (optional), odometer, battery volt, speedometer, tachometer, transmission autoshifting indicator, Warning lights: air filter restriction, brake oil low pressure, communication system error, discharge warning, engine oil low pressure, engine warning, hydraulic oil level, low steering oil pressure, overheat, transmission warning	●
Indicator on sub monitor : payload checker, dual auto-leveler indicator rear obstacle detection and warning system (optional)	●
38 languages selection	●

## ELECTRICAL SYSTEM

Alternator (95A)	●
Backup alarm	●
Battery disconnect switch	●
Large capacity batteries	●
Power outlet 12 V & 24 V	●

## LIGHTS

Clearance lights	●
LED brake & tail lights	●
LED headlights	●
Rotating lamp	○
Turn signals with hazard switch	●
Work lights	
2 front on cab & 2 rear LED working lights	●
2 front on cab & 2 rear LED working lights (High brightness)	○
4 front, 2 rear on cab & 2 rear LED working lights	○
4 front, 2 rear on cab & 2 rear LED working lights (High brightness)	○

## POWER TRAIN

Approach speed control	●
Automatic transmission with load sensing system	●
Clutch cut position switch	●
Differential	
LSD (Limited Slip Differential, front and rear)	○
TPD (Torque Proportioning Differential, front and rear)	●
DSS (Down Shift Switch)	●
Forward/Reverse lever	●
Forward/Reverse selector switch	●
Lock-up clutch (torque converter)	●
Maximum gear limited switch	●
Power mode switch	●
Quick power switch	●
Travel mode selector (Auto1-Auto2)	●

## TIRES

26.5R25(L3) XHA2	●
26.5R25(L5) XLDD2A	○
26.5R25(L5) XMINED2 PRO	○

## MISCELLANEOUS

Articulation lock bar	●
Auto lubrication system	○
Belly guard (Bolt on type) (front / rear)	○
Bucket cylinder guard	○
Cab top rail	
Front rail on the cab top	●
Rear rail on the cab top	●
Cab window cleaning foot plate	●
Counterweight, built-in	●
Cutting edge protection	○
Drawbar with locking plate	●
Emergency steering	●
Fenders	
for 26.5R25 (Front and full covered rear fenders with mud flaps)	●
Front windshield guard	○
Global e-Service	●
Lift arm	
High lift arm	○
Standard lift arm	●
Lift & tie down hooks	●
On board information controller	●
Pilfer proof	
Battery cover with locking bracket	○
Lockable engine cover	●
Lockable fuel refilling cap	○
Standard tool kit	●
Tool box	●
Under cover (Bolt on type) (rear x2)	●
Wheel blocks	○

Prior to operating this machine, including satellite communication system, in a country other than a country of its intended use, it may be necessary to make modifications to it so that it complies with the local regulatory standards (including safety standards) and legal requirements of that particular country. Please do not export or operate this machine outside the country of its intended use until such compliance has been confirmed. Please contact your Hitachi dealer in case of questions about compliance.

These specifications are subject to change without notice. Illustrations and photos show the standard models, and may or may not include optional equipment, accessories, and all standard equipment with some differences in colour and features. Before use, read and understand the Operator's Manual for proper operation.

