



ZW160-7

The ZW160-7 wheel loader has been designed to help you control your profitability by reducing your running costs. It also prioritises your comfort and safety in its industry-leading cab and maximises uptime thanks to its reliable performance. You can also expect unrivalled levels of support from Hitachi throughout its life cycle.

You can work on a wide range of projects with the versatile Hitachi ZW160-7 wheel loader. The engine output and tipping load are increased which results significant better performance while maintaining low consumption levels.

Engine rated power : 123 kW / 165hp@2.200rpm's (ISO14396)

Operating weight : 13 020 kg

Bucket ISO heaped : 2.00 – 3.60 m³

Available in : Europe

Discover the benefits

- ✓ Engine output is enhanced by 15%
- ✓ Performance level is improved thanks to a large number of new functions such as Approach Speed Control and Traction Control System
- ✓ Industry-leading comfort with the new seat mounted control levers and 8-inch wide monitor
- ✓ Superior view of the surroundings and enhanced safety thanks to the optional Aerial-Angle camera system and the rear obstacle detection and warning system.

Attachments enhance the performance of your ZW160-7

- ✓ Choose from a wide range of Hitachi attachments, such as bucket's, pallet forks, high volume and high tip buckets to suit the application.
- ✓ Hitachi ground engaging tools (GET) fit precisely to your attachments, and are quick and safe to install and replace.

Try before you buy with Hitachi Premium Rental

- ✓ You can rent a wide range of Hitachi excavators and wheel loaders direct from Hitachi via our dealer network. Hitachi Premium Rental machines can be hired by the month and for periods up to one year. This gives you the high levels of reliability, quality and service you would expect from Hitachi, and greater flexibility to meet the varying demands of your business.

Want to find out more?

- ✓ For more information on the new Zaxis-7 series of wheel loader's, the Hitachi Premium Rental programme, or to discuss your needs in more detail, please complete the form below. One of our specialists will contact you within a few working days of your enquiry.

SPECIFICATIONS

Preliminary specifications – subject to change

ENGINE

Model	CUMMINS B4.5
Type	4-cycle water-cooled, direct injection
Aspiration	Turbocharger and intercooled
Aftertreatment	DPF and SCR system
No. of cylinders	4
Maximum power	
ECE R120, gross	126 kW (169 hp) at 2 000 min ⁻¹ (rpm)
ISO 9249: 2007, net	124 kW (166 hp) at 2 000 min ⁻¹ (rpm)
Rated power	
ISO 14396: 2002	123 kW (165 hp) at 2 200 min ⁻¹ (rpm)
ISO 9249: 2007, net	122 kW (163 hp) at 2 200 min ⁻¹ (rpm)
Maximum torque	
ISO 9249: 2007, net	755 Nm at 1 200 min ⁻¹ (rpm)
Bore and stroke	107 mm X 124 mm
Piston displacement	4.46 L
Batteries	2 x 12 V
Air cleaner	Two element dry type with restriction indicator

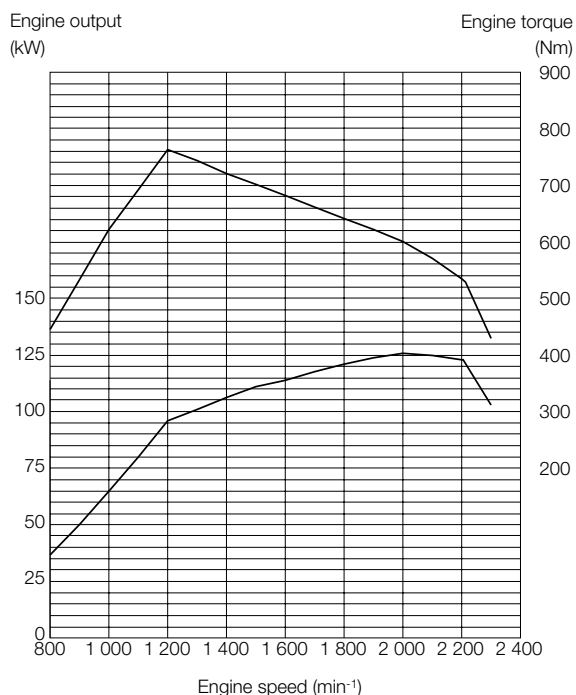

POWER TRAIN

Transmission	Electrical-controlled 2 motor hydrostatic transmission with summation gear box, Gear box : Fixed gear ratio, powershift countershaft type
Cooling method	Forced circulation type
Travel speed* Forward / Reverse	
1st	13 / 13 km/h (13 / 13 km/h)
2nd	13 / 13 km/h (13 / 13 km/h)
3rd	20 / 20 km/h (20 / 20 km/h)
4th	39 / 39 km/h (39 / 39 km/h)
*With 20.5 R25 (L3) tires	
() : Data at Power Mode	

AXLE AND FINAL DRIVE

Drive system	Four-wheel drive system
Front & rear axle	Semi-floating
Front	Fixed to the front frame
Rear	Trunnion support
Reduction and differential gear	Two stage reduction with torque proportional differential
Oscillation angle	Total 20° (+10°, -10°)
Final drives	Heavy-duty planetary, mounted inboard

TIRES

Tire size	20.5R25 (L3)
-----------------	--------------

BRAKES

Service brakes	Inboard mounted fully hydraulic 4 wheel wet disc brakes. Front & rear independent brake circuit, HST (Hydro Static Transmission) system provides additional hydraulic braking capacity
Parking brakes	Spring applied, hydraulically released, wet disc type

STEERING SYSTEM

Type	Articulated frame steering
Steering angle	Each direction 40° ; total 80°
Cylinders	Double-acting piston type
No. x Bore x Stroke	2 x 65 mm x 419 mm

HYDRAULIC SYSTEM

Arm and bucket are controlled by multifunction lever	
Arm controls	Four position valve; raise, hold, lower, float
Bucket controls with automatic bucket return-to-dig control	Three position valve; roll back, hold, dump
Main pump (Serve as steering pump)	
..... Gear type	
Maximum flow	194 L/min at 2 200 min ⁻¹ (rpm)
Maximum pressure ..	20.6 MPa
Brake & fan & pilot oil pump	
..... Gear type	
Maximum flow	44.9 L/min at 2 200 min ⁻¹ (rpm)
Maximum pressure ..	15.5 MPa
ZW160-7 Hydraulic cylinders	
Type	Double acting type
No. x Bore x Stroke ...	Arm : 2 x 125 mm x 760 mm Bucket : 1 x 150 mm x 495 mm
Filters	Full-flow 10 micron return filter in reservoir
ZW160PL-7 Hydraulic cylinders	
Type	Double acting type
No. x Bore x Stroke ...	Arm : 2 x 125 mm x 760 mm Bucket : 2 x 110 mm x 1 005 mm
Filters	Full-flow 10 micron return filter in reservoir
Hydraulic cycle times	
Lift arm raise	ZW160-7 : 5.9 s ZW160PL-7 : 6.2 s
Lift arm lower	ZW160-7 : 3.8 s ZW160PL-7 : 3.6 s
Bucket dump	ZW160-7 : 1.4 s ZW160PL-7 : 3.4 s
Total	ZW160-7 : 11.1 s ZW160PL-7 : 13.2 s
*Data at Power Mode	

HYDRAULIC SYSTEM / HST

HST charging pump	
..... Gear type	
Maximum flow	53.9 L/min at 2 200 min ⁻¹ (rpm)
Maximum pressure ..	2.45 MPa
Relief pressure setting	20.6 MPa
Transmission charging pump	
..... Gear type	
Maximum flow	17.6 L/min at 2 200 min ⁻¹ (rpm)
Maximum pressure ..	1.96 MPa

ENVIRONMENT

Engine Emissions	
Complies with EU stage V	
Sound level	
External sound level according To ISO 6395: 2008 and EU Directive 2000/14/EC	104 LwA dB(A)
Sound level in cabin according to ISO 6396: 2008.....	67 LpA dB(A)
Air Conditioning System	
The air conditioning system contains fluorinated greenhouse gases.	
Refrigerant type: HFC-134a, GWP: 1430, Amount: 0.75±0.05kg, CO2e: 1.07±0.07ton.	

SERVICE REFILL CAPACITIES

Fuel tank	205 L
Engine coolant	20 L
Engine oil (Including oil pan)	16 L
Front axle differential & wheel hubs	25 L
Rear axle differential & wheel hubs	25 L
Hydraulic oil tank	80 L
DEF/AdBlue® tank	18 L

DIMENSIONS & SPECIFICATIONS ZW160-7

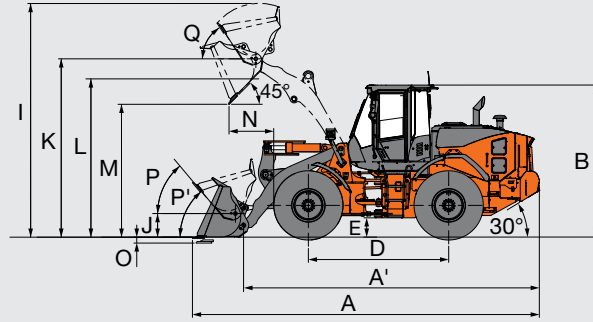
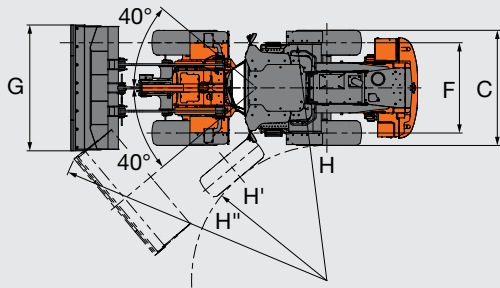

Bucket type			Standard arm					High-lift arm			
			General purpose								
			Weld-on teeth	Bolt-on cutting edge	Weld-on teeth	Bolt-on cutting edge	Bolt-on cutting edge	Weld-on teeth	Bolt-on cutting edge	Weld-on teeth	Bolt-on cutting edge
Bucket capacity	ISO 7546: 1983 Heaped	m ³	2.2	2.2	2.4	2.4	3.6	2.0	2.0	2.2	2.2
	ISO 7546: 1983 Struck	m ³	1.8	1.8	2.0	2.0	3.1	1.6	1.6	1.8	1.8
A Overall length		mm	7 670	7 515	7 720	7 565	7 810	8 110	7 955	8 160	8 005
A' Overall length (Without Bucket)		mm	6 420	6 420	6 420	6 420	6 420	6 905	6 905	6 905	6 905
B Overall height	up to cab top	mm	3 280	3 280	3 280	3 280	3 280	3 280	3 280	3 280	3 280
C Width over tires	outside tire	mm	2 500	2 500	2 500	2 500	2 500	2 500	2 500	2 500	2 500
D Wheel base		mm	3 000	3 000	3 000	3 000	3 000	3 000	3 000	3 000	3 000
E Ground clearance	Minimum	mm	430	430	430	430	430	430	430	430	430
F Tread		mm	1 930	1 930	1 930	1 930	1 930	1 930	1 930	1 930	1 930
G Bucket width		mm	2 535	2 535	2 535	2 535	2 700	2 535	2 535	2 535	2 535
H Turning radius (Centerline of outside tire)		mm	5 085	5 085	5 085	5 085	5 085	5 085	5 085	5 085	5 085
H' Turning radius to inside of tires		mm	2 870	2 870	2 870	2 870	2 870	2 870	2 870	2 870	2 870
H'' Loader clearance radius, bucket in carry position		mm	5 980	5 940	5 995	5 955	6 100	6 180	6 130	6 195	6 150
I Overall operating height	bucket full raise	mm	5 040	5 040	5 110	5 110	5 455	5 350	5 350	5 415	5 415
J Carry height of bucket pin	at carry position	mm	385	385	385	385	385	385	385	385	385
K Height to bucket hinge pin, fully raised		mm	3 840	3 840	3 840	3 840	3 840	4 210	4 210	4 210	4 210
L Lift arm clearance at max. lift		mm	3 570	3 550	3 570	3 550	3 550	3 940	3 920	3 940	3 920
M Dumping clearance 45 deg, full height		mm	2 690	2 795	2 655	2 760	2 590	3 095	3 200	3 060	3 165
N Reach 45 deg dump, full height		mm	1 145	1 010	1 185	1 045	1 215	1 300	1 160	1 335	1 200
O Digging depth (Horizontal digging angle)		mm	80	105	80	105	105	205	225	205	225
P Max. roll back at carry position		deg	46	46	46	46	46	47	47	47	47
P' Max. roll back at ground level		deg	43	43	43	43	43	44	45	44	45
Q Roll back angle at full height		deg	59	59	59	59	59	54	54	54	54
Static tipping load ISO 14397-1: 2007(Section 1-5) *	Straight	kg	10 610	10 480	10 530	10 450	10 410	8 490	8 390	8 450	8 340
	Full turn	kg	9 210	9 090	9 140	9 050	9 020	7 330	7 240	7 300	7 190
Breakout force		kN	105	99	99	94	77	103	97	98	92
		kgf	10 690	10 080	10 120	9 570	7 800	10 490	9 880	9 950	9 390
Operating weight * (With ROPS / FOPS Cab)		kg	12 910	12 980	13 020	13 090	13 060	13 080	13 150	13 120	13 190

Note: All dimensions, weight and performance data based on ISO 6746-1 : 1987, ISO 7137 : 2009 and ISO 7546 : 1983

: Static tipping load and operating weight marked with include 20.5R25 (L3) tires (No ballast) with lubricants, full fuel tank and operator.

Machine stability and operating weight depend on counterweight, tire size and other attachments.

WEIGHT CHANGE

Option item		Operating weight (kg)	Tipping load (kg)		Overall width (mm) (outside tire)	Overall height (mm)	Overall length (mm)
			Straight	Full turn			
Tire	20.5R25 (L3) XHA2	±0	±0	±0	±0	±0	±0
	20.5R25 (L5) XLD D2A	+460	+340	+300	+15	+30	-20
	20.5R25 (L5) XMINE D2 PRO	+620	+460	+400	+10	+35	-25
	20.5R25 (L2) XSNOPPLUS	±70	±50	±50	+5	-10	+10
	20.5R25 (L3) VJTZ	+10	+10	+10	±0	-5	+5
	20.5R25 (L3) TL-3A+	+150	+110	+100	+15	-5	+5
Belly guard		+70	+40	+40	±0	±0	±0

BUCKET SELECTION GUIDE

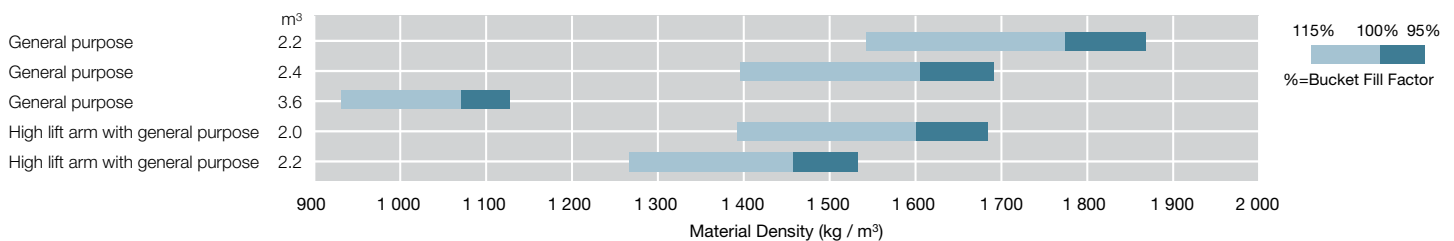

SPECIFICATIONS

Preliminary specifications – subject to change

DIMENSIONS & SPECIFICATIONS ZW160PL-7

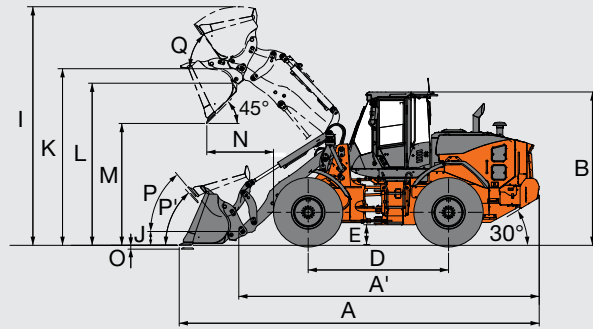
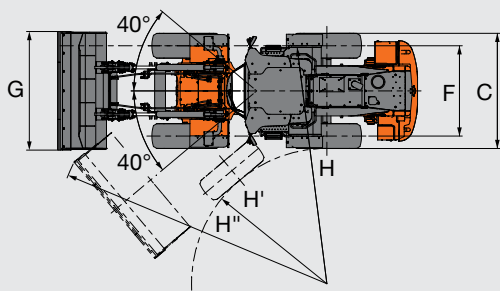

Bucket type		General purpose				
		Weld-on teeth		Bolt-on cutting edge		
Bucket capacity	ISO 7546: 1983 Heaped	m ³	2.1	2.1	2.2	2.2
	ISO 7546: 1983 Struck	m ³	1.8	1.8	1.9	1.9
A Overall length		mm	7 915	7 765	7 920	7 760
A' Overall length (Without Bucket)		mm	6 565	6 565	6 565	6 565
B Overall height	up to cab top	mm	3 280	3 280	3 280	3 280
C Width over tires	outside tire	mm	2 500	2 500	2 500	2 500
D Wheel base		mm	3 000	3 000	3 000	3 000
E Ground clearance	Minimum	mm	430	430	430	430
F Tread		mm	1 930	1 930	1 930	1 930
G Bucket width		mm	2 535	2 535	2 535	2 535
H Turning radius (Centerline of outside tire)		mm	5 085	5 085	5 085	5 085
H' Turning radius to inside of tires		mm	2 870	2 870	2 870	2 870
H'' Loader clearance radius, bucket in carry position		mm	6 055	6 010	6 055	6 010
I Overall operating height	bucket full raise	mm	5 280	5 280	5 320	5 320
J Carry height of bucket pin	at carry position	mm	390	390	390	390
K Height to bucket hinge pin, fully raised		mm	3 975	3 975	3 975	3 975
L Lift arm clearance at max. lift		mm	3 690	3 665	3 690	3 665
M Dumping clearance 45 deg, full height		mm	2 650	2 755	2 645	2 760
N Reach 45 deg dump, full height		mm	1 415	1 280	1 420	1 275
O Digging depth (Horizontal digging angle)		mm	105	125	105	125
P Max. roll back at carry position		deg	47	47	47	47
P' Max. roll back at ground level		deg	44	45	44	45
Q Roll back angle at full height		deg	53	53	53	53
Bucket weight		kg	950	1 020	950	1 010
Static tipping load ISO 14397-1: 2007(Section 1-5) *	Straight	kg	9 680	9 570	9 770	9 680
	Full turn	kg	8 360	8 250	8 440	8 350
Breakout force		kN	105	100	104	101
		kgf	10 670	10 210	10 620	10 250
Operating weight * (With ROPS / FOPS Cab)		kg	13 540	13 610	13 530	13 600

WITH FORK ATTACHMENT

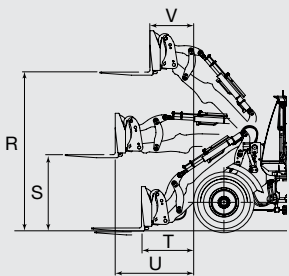

Attachment type		Fork
R	Max. stacking height	mm
S	Height of fork at maximum reach	mm
T	Reach at ground level	mm
U	Max. reach	mm
V	Reach at max. stacking height	mm
Static tipping load	Straight	kgf
	Full 40 degree turn	kgf
Max. payload per EN 474-3, 80 %		kg
Max. payload per EN 474-3, 60 %		kg
Fork tine length		mm
Operating weight *		kg

Note: *: Static tipping load and operating weight marked with* include 20.5R25 (L3) tires (No ballast) with lubricants, full fuel tank and operator. Machine stability and operating weight depend on counterweight, tire size and other attachments.

WEIGHT CHANGE

Option item	Operating weight (kg)	Tipping load (kg)		Overall width (mm) (outside tire)	Overall height (mm)	Overall length (mm)
		Straight	Full turn			
Tire	20.5R25 (L3) XHA2	±0	±0	±0	±0	±0
	20.5R25 (L5) XLD D2A	+460	+290	+260	+15	+30
	20.5R25 (L5) XMINE D2 PRO	+620	+390	+350	+10	+35
	20.5R25 (L2) XSNOPLUS	±70	+40	+40	+5	-10
	20.5R25 (L3) VJTZ	+10	+10	+10	±0	-5
	20.5R25 (L3) TL-3A+	+150	+100	+80	+15	-5
Belly guard	+70	+40	+30	±0	±0	±0

BUCKET SELECTION GUIDE

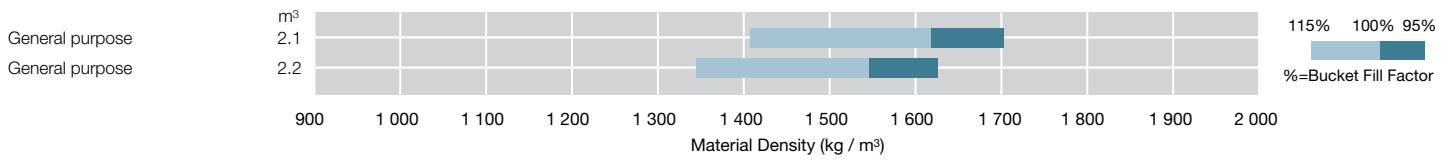

EQUIPMENT

Preliminary specifications – subject to change

● : Standard equipment ○ : Optional equipment – : Not applicable

ENGINE	ZW160-7	ZW160PL-7
Aftertreatment device	●	●
Aftertreatment manual regeneration inhibit switch	●	●
Aftertreatment manual regeneration switch	●	●
Air filter double elements	●	●
Air intake		
Pre-cleaner (Sy-Klone type)	●	●
Pre-cleaner (Turbo II)	○	○
Anti-clogging radiator (Wide fin pitch)	●	●
Automatic reversible cooling fan with heat sensing	●	●
Cartridge-type engine oil filter	●	●
Cartridge-type fuel main filter	●	●
Cartridge-type fuel pre-filter (with water separator function)	●	●
Coolant reservoir sight gauge	●	●
DEF/AdBlue® tank with magnet adapter	●	●
Engine auto shut-down control system	●	●
Engine oil remote drain	●	●
Fan guard	●	●

BRAKE SYSTEM		
Front & rear independent brake circuit	●	●
Inboard mounted fully hydraulic 4 wheel wet disc	●	●
Spring applied/Hydraulic-released parking brake	●	●

HYDRAULIC SYSTEM		
Bucket auto leveler (Automatic return to dig control)	●	●
Control lever lock switch	●	●
Dual lift arm auto leveler and kickout system	●	●
Electric Control lever		
for 3 spools control valve		
MF lever & Proportional switch for 3rd function	●	●
for 4 spools control valve		
MF lever & 2 Proportional switch for 3rd & 4th function	○	–
Hydraulic filters	●	●
Lift arm float system	●	●
Quick coupler piping and switch	○	●
Reservoir sight gauge	●	●
Ride control system (OFF-AUTO type)	●	●
Work mode selector	●	●

CAB	ZW160-7	ZW160PL-7
Adjustable steering column with POP-UP	●	●
Auto control air conditioner		
Pre-cleaner for air conditioner	○	○
with double intake filters	●	●
Bluetooth® integrated DAB+radio, hands-free calling	●	●
Camera & monitor		
AERIAL ANGLE® (Side and rear view camera)	○	○
Rear view camera & monitor	●	●
Coat hook	●	●
Evacuation hammer	●	●
Front/Rear defroster	●	●
Glove compartment	●	●
LED room light	●	●
Payload checker with tip-off function	●	–
Rear obstacle detection system	○	○
Rear obstacle detection system (Automatic speed reduction)	○	○
Rear view mirrors		
Inside (1)	●	●
Outside (Heated, 2) electrical adjustment with proximity	●	●
Retractable seat belt, 50 mm	●	●
ROPS (ISO 3471:2008), FOPS (ISO 3449:2008 LEVEL II): multi-plane isolation mounted for noise, vibration reduction	●	●
Rubber floor mat	●	●
Seat		
Heavy Duty air suspension seat equipped with horizontal suspension, headrest and heater: fabric, high back, adjustable for damper, inclination of the seat, seat depth, weight-height, fore-aft position, reclining angle, armrest angle, headrest height and angle, lumbar support	●	●
Seat belt reminder	●	●
Steering system		
Wheel steering	●	●
Storage		
Cup holder	●	●
Document holder	●	●
Hot & cool box	●	●
Seatback pocket	●	●
Smartphone and Tablet device holder	●	●
Sun shade film on front windshield	○	○
Sunscreen roller type	●	●
Textured steering wheel with spinner knob	●	●
Tinted safety glass		
Front windshield: laminated	●	●
Others: tempered	●	●
USB power supply	●	●
Windshield washer front and rear	●	●
Windshield wipers front and rear	●	●
2 speakers	●	●
8 inch sub monitor	●	●

● : Standard equipment ○ : Optional equipment — : Not applicable

MONITORING SYSTEM	ZW160-7	ZW160PL-7
Gauge: coolant temperature, fuel level, transmission oil temperature	●	●
Indicator lights : clearance lights, control lever lock, fuel level, high beam, parking brake, preheat, turn signals, work lights, fan reverse indicator, seat belt indicator	●	●
Indicator on multifunction monitor: F-N-R shift position, gear shift position, clock, DEF alarm indicator, DEF level gauge, ECO indicator, forward/reverse selector switch indicator, hold display, hour meter, odometer, battery volt, speedometer, tachometer, transmission auto-shifting indicator, Warning lights: air filter restriction, brake oil low pressure, communication system error, discharge warning, engine oil low pressure, engine warning, hydraulic oil level, low steering oil pressure, overheat, transmission warning	●	●
Indicator on sub monitor : payload checker (excluding PL), dual auto-leveler indicator rear obstacle detection and warning system (optional)	●	●
38 languages selection	●	●

ELECTRICAL SYSTEM		
Alternator (95A)	●	●
Backup alarm	●	●
Battery disconnect switch	●	●
Large capacity batteries	●	●
Power outlet 12 V and 24 V	●	●

LIGHTS		
Clearance lights	●	●
LED brake & tail lights	●	●
LED headlights	●	●
Rotating lamp	○	○
Turn signals with hazard switch	●	●
Work lights		
2 front on cab & 2 rear LED working lights	●	●
2 front on cab & 2 rear LED working lights (High brightness)	○	○
4 front, 2 rear on cab & 2 rear LED working lights	○	○
4 front, 2 rear on cab & 2 rear LED working lights (High brightness)	○	○

POWER TRAIN		
Approach speed control	●	●
Deceleration select switch	●	●
Differential		
LSD (Limited Slip Differential, front and rear)	○	○
TPD (Torque Proportioning Differential, front and rear)	●	●
Driving speed limiter (20km/h)	○	○
Electrically controlled HST system	●	●
Forward/Reverse lever	●	●
Forward/Reverse selector switch	●	●
Power mode switch	●	●
Traction control switch	●	●
1st speed limited switch	●	●

TIRES	ZW160-7	ZW160PL-7
20.5R25 (L2) XSNOPLUS	○	○
20.5R25 (L3) TL-3A+	○	○
20.5R25 (L3) VJT	○	○
20.5R25 (L3) XHA2	●	●
20.5R25 (L5) XLDD2A	○	○
20.5R25 (L5) XMINED2 PRO	○	○

MISCELLANEOUS		
Articulation lock bar	●	●
Belly guard (Bolt on type) (front / rear)	○	○
Bucket cylinder guard	○	○
Cab top rail		
Front rail on the cab top	●	●
Rear rail on the cab top	●	●
Counterweight, built-in	●	●
Cutting edge protection	○	○
Drawbar with locking pin	●	●
Emergency steering	●	●
Fenders		
for 20.5 R25 (Front & full covered rear fenders with mud flaps)	●	●
Global e-Service	●	●
Lift & tie down hooks	●	●
Lift arm		
High lift arm	○	—
Parallel lift arm	—	●
Standard lift arm	●	—
On board information controller	●	●
Pilfer proof		
Battery cover with locking bracket	●	●
Lockable engine cover	●	●
Lockable fuel refilling cap	●	●
Quick coupler	—	●
Radiator dust protection screen	○	○
Rear licence plate bracket	○	○
Road homologation		
German road homologation kit: rear license plate bracket, reflective sticker, wheel blocks	○	○
Italian road homologation kit: cab lights, bucket cutting edge protection, link stopper, rear license plate bracket, reflective sticker, rotating lamp	○	○
Spanish road homologation kit: rear license plate bracket, rotating lamp	○	○
Standard tool kit	●	●
Wheel blocks	○	○

Prior to operating this machine, including satellite communication system, in a country other than a country of its intended use, it may be necessary to make modifications to it so that it complies with the local regulatory standards (including safety standards) and legal requirements of that particular country. Please do not export or operate this machine outside the country of its intended use until such compliance has been confirmed. Please contact your Hitachi dealer in case of questions about compliance.

These specifications are subject to change without notice. Illustrations and photos show the standard models, and may or may not include optional equipment, accessories, and all standard equipment with some differences in color and features. Before use, read and understand the Operator's Manual for proper operation.

