

EH5000

HITACHI

EH5000

Nominal Payload with Standard Equipment

284 tonnes (312 tons)

Maximum GMW

528 208 kg (1 164 500 lb)

Engine

Detroit Diesel 16V-4000

Rated Power 2014 kW (2700 HP)

Cummins QSK60-L is available as an option.



Engineered for Performance, Designed for Comfort, and Built to Last.

Hitachi EH5000 is designed with the same reliability as Hitachi's world leading Hydraulic Excavators.

AC Drive Proven Performance & Economic Advantages

Hitachi adopted Siemens AC drives make your hauler a more valuable asset in your mining operation. Better performance, higher availability, and significant reductions in maintenance and operating costs - result in a lower cost per tonne and a higher return on your investment.

High-Powered Engine

You can choose the Detroit Diesel w/DDEC IV engine, model 16V-4000 with 2 014 kW and 10 930 N·m torque or the Cummins QSK60-L engine with 2 014 kW and 10 630 N·m torque as an option.

Long Frame Life

A fabricated box section and rectangular frame rail construction provides superior resistance to bending and torsional loads. One-piece top and bottom flanges eliminate cross tie member tie-in joints and provide a larger exposed center area for access to major components. There are no castings in the frame assembly.

Tough Body

The Hitachi horizontal stiffener design minimizes stress concentrations, by dissipating load shocks over the entire body length. Closely spaced stiffeners provide additional protection by minimizing distances between unsupported areas.

Note : The loadweight displays are optional.



Well Matched: EH5000 & Excavators

Excavator	EX3600-5		EX5500-5		EX8000
	LD	BH	LD	BH	LD
Bucket	21.0 m ³ (27.5yd ³)	22.0 m ³ (28.8yd ³)	27.0 m ³ (35.5yd ³)	29.0 m ³ (38.0yd ³)	40.0 m ³ (52.3yd ³)
Passes	8 or 9	8	6 or 7	6	4

LD: Loading shovel BH: Backhoe

AC Drive Advantage

Hitachi AC drive technology, developed in conjunction with Siemens, provides superior performance with higher top speeds, better gradeability and stronger retardation.

These features increase productivity and availability, and reduce operating and maintenance cost.

Lower maintenance costs are achieved with use of brushless motors and elimination of contactors. The Siemens AC motors do not have commutators, reducing costs and allowing the truck to achieve higher speeds. Less downtime and higher speeds result in more production and lower cost per tonne.

Siemens AC drive systems power not only rigid haul trucks, but also electric rope shovels, train locomotives and draglines.



Full retarding capability

Hitachi AC drive systems are virtually maintenance-free and provide higher top speeds and more rimpull than a comparable DC system. Full retarding capability means the truck can be fully stopped without applying the service brakes.

The AC drive traction motors

Hitachi's Double Path Epicyclic Planetary Design provides high efficiency and easy maintenance. Allowing the 1st (outer) planetary carrier to travel at wheel speed provides lower operating temperatures - longer lubricant life, better component life. Increased 2nd (inner) planetary gears, from 3 to 4, produce higher reliability.

Full retarding capability

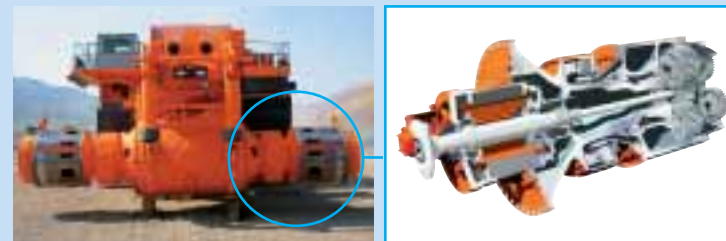
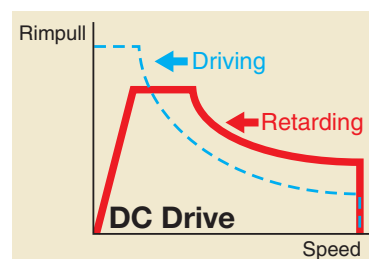
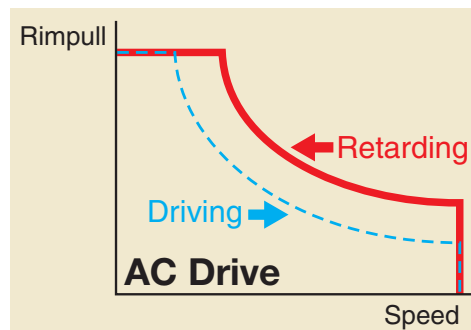

Grid box & Siemens control unit

Grid box located lower position provides better right hand visibility. Control unit with higher efficient liquid cooling system makes the size compact, therefore provides better visibility.



Note : The loadweight displays are optional.

Ease of Operation



COMMAND CAB III

Double wall construction of 11 gauge inner and outer steel panels produces a more structurally sound cab. Foam rubber lining material along with foam rubber backed carpeting and multiple layered floor mat act to absorb sound and control interior temperature. A properly maintained cab from Hitachi, tested with doors and windows closed per work cycle procedures in SAE J1166, results in an operator sound exposure Leq (Equivalent Sound Level) of 81 dB(A). A three-point rubber iso-mount arrangement to the deck surface minimizes vibration to the operator compartment.



Superior Suspension

The Hitachi ACCU-TRAC suspension system delivers excellent maneuverability, even at higher speeds. The trailing arm layout offers greater ease of servicing while improving truck performance compared to suspended king-pin designs. The pivot mounting of the trailing arm design allows only axial input to the strut and allows wheel movement to the vertical plane only.

Features:

- Lateral forces that act on the front wheels are minimized, resulting in reduced tire scuffing.
- Dynamic friction (side-wall force) within the strut is low due to the features of the ACCU-TRAC design, allowing the use of a lighter strut engineered to a smaller diameter and longer stroke.
- The necessary frame bulk (horse-collar structure) needed to mount a suspended king-pin is non-existent.

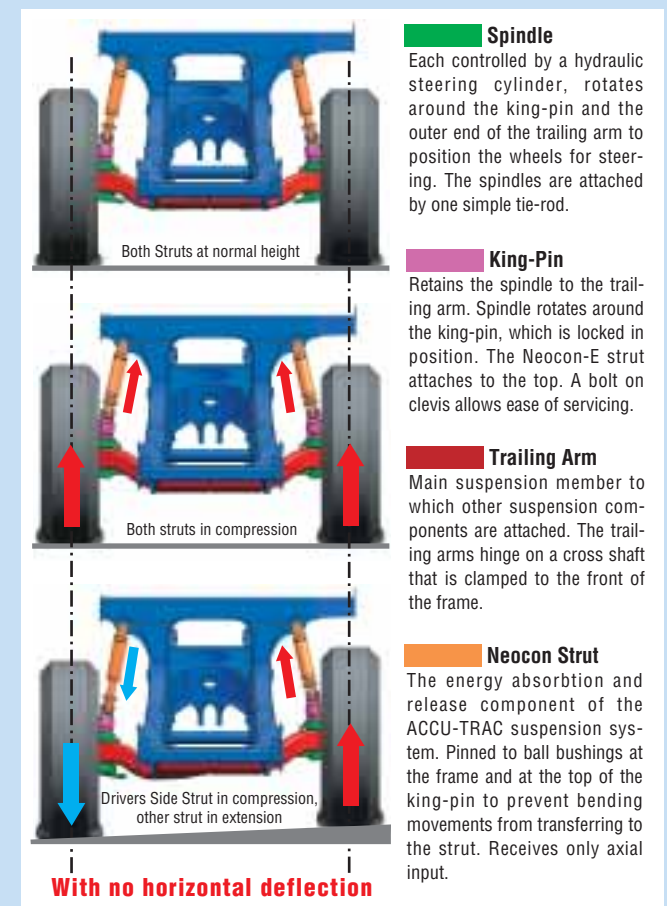

Auto-Lubrication System

A pump fed system automatically applies grease to lube points via plumbing. The lubricant is automatically delivered in time controlled and metered quantities to all connected lube points in the system.



- The elimination of the "horse-collar" member provides greater engine access.
- The NEOCON strut used with the ACCU-TRAC suspension, improves operator and component isolation, provides better hauler stability and predictable operational control.
- Locating the king-pin close to the wheel assembly and at a slight angle results in low "Dry Park Steering" effort.
- Development of the compressible media, NEOCON-E™ fluid (proprietary, silicone based, environmentally friendly) for use in the suspension strut with Helium gas, results in an improved energy absorption (isolation) system and an improved energy release (stability) system that responds favorably whether traveling empty or with payload in a wide range of ambient temperatures.

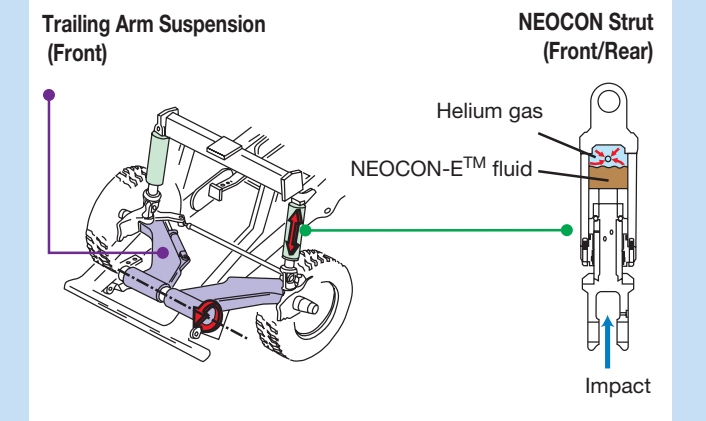

The ACCU-TRAC suspension design allows the front struts to be removed and installed without removing the trailing arms, brakes or tires. This relates to fewer tools and less labour required to perform the repair, which aims to reduce the amount of hauler downtime, increasing productivity.



Centralized Fire Suppression System (Optional)

This dry chemical fire suppression system can be activated manually or automatically. Immediately upon activation the dry chemical agent is expelled from many strategically placed nozzles.



Specifications: EH5000



ENGINE

Standard

Model	Detroit Diesel w/DDEC IV 16V-4000
Type	4 Cycle
Aspiration	Turbocharged & low temperature aftercooled
Emission Certification	U.S. EPA Tier 1

Gross Power @1900 min ⁻¹ (rpm)	
(SAE J1995)	2 014 kW (2 700 HP)
Net power @1900 min ⁻¹ (rpm)	
(SAE J1349)	1 939 kW (2 600 HP)
Maximum Torque @1 500 min ⁻¹ (rpm)	
	10 930 N.m (1 115 kgf-m, 8 062 lbf-ft)
No. Cylinders	16
Bore & Stroke	165 x 190 mm (6.5 in x 7.48 in)
Displacement	65 L (3 967 in ³)
Starting	24 Volt Electric

Optional

Model	Cummins QSK60-L
Type	4 Cycle
Aspiration	Two-stage turbocharged intercooled & low temperature aftercooled
Emission Certification	U.S. EPA Tier 1

Rated Power @1900 min ⁻¹ (rpm)	
(SAE J1995)	2 014 kW (2 700 HP)
Net power @1900 min ⁻¹ (rpm)	
(SAE J1349)	1 920 kW (2 575 HP)
Maximum Torque @1 500 min ⁻¹ (rpm)	
	10 630 N.m (1 084 kgf-m, 7 840 lbf-ft)
No. Cylinders	16
Bore & Stroke	159 x 190 mm (6.26 in x 7.48 in)
Displacement	60.2 L (3 674 in ³)
Starting	24 Volt Electric



ELECTRIC DRIVE

	Standard	Optional
Planetary Ratio	35.816:1	40.789:1
Maximum Speeds	66.9 km/h (41.6 mph)	56.2 km/h (34.9 mph)



TIRES

Standard - Front and Rear	Rim Width
53/80R63(**) E4 Radial	965 mm (38 in)

Certain job conditions may require higher TKPH(TMPH) in order to maintain maximum production. Hitachi recommends evaluating the job conditions and consulting the tire manufacturer to make proper tire selection. Optional rims available.



ELECTRICAL SYSTEM

Twenty-four volt system. 260-ampere battery charger. Eight 12-volt, heavy-duty batteries connected in series/parallel.



BODY CAPACITY

Struck (SAE)	m ³ (yd ³)
Heap 3:1	143.6 (187.8)
Heap 2:1 (SAE)	179.5 (234.8)
	196.1 (256.5)

Body capacity and payload subject to change based on customer specific material density and application.



STEERING SYSTEM

Flow-amplified, closed-center hydrostatic power steering system using two double-acting cylinders with pressure unloading type compensated piston pump and a brake actuation/steering system reservoir. Dual-Hitachi accumulators provide supplementary steering in accordance with J/ISO 5010 and constant steering rate under all conditions. A Tilt/telescopic steering wheel with 35 degrees of tilt and 57.15 mm (2.25") telescopic travel is standard.

Steering Angle	40°
Turning Diameter (SAE)	30.15 m (98'11" in)
Steering Pump Output	
(@ 1900 min ⁻¹ (rpm))	249.0 L/min (65.8 gpm)
System Pressure	20 685 kPa (3 000 psi)
Filtration - pressure line	
Beta 6 ratio = 200	



WEIGHTS

	Detroit Diesel		Cummins	
	kg	(lb)	kg	(lb)
Chassis with Hoist	167 865	(370 078)	168 782	(372 101)
Net Machine Weight	213 185	(469 991)	214 102	(472 014)
Net Axle Weights				
Front Axle(49-51%)	104 475	(230 327)	105 749	(233 136)
Rear Axle(49-51%)	108 710	(239 664)	108 353	(238 878)

Maximum GMW	528 208	(1 164 500)	528 208	(1 164 500)
[53/80 R63(**)E4]				
Including Options, 50% Fuel, Operator & Payload Not to Exceed.				
Weights given are for standard options, standard body and tires.				
Net machine weight changes will directly effect the payload.				
Material density will determine body volume figures.				

Load Weight Distribution				
Front - 32%	170 781	(376 508)	171 860	(378 886)
Rear - 68%	357 427	(787 992)	356 349	(785 614)

Payload with Standard Equipment	315 tonnes (347 tons)
---------------------------------	-----------------------

Note: Nominal Payload on front cover shows 90% of Payload with Standard Equipment.



HYDRAULIC SYSTEM

Two (2) Hitachi three-stage, double-acting cylinders, with cushioning in retraction, containing dual rod seals and urethane energized scrapers, inverted and outboard mounted. Separate reservoir and tandem gear pump connects with a four position electronic pilot controlled hoist valve. Electric controller is mounted to operator's seat.

Body Raise Time	22 s
Body Down Time	24 s
Hoist Pump Output Total (@ 1900 min ⁻¹ (rpm))	969 L/min (256 gpm)
System Relief Pressure	21 030 kPa (3 050 psi)
Filtration - pressure line	
Beta 6 ratio = 200	



BRAKE SYSTEM

Brake systems meet or surpass SAE J/ISO 3450.

Service

All-hydraulic actuated braking system provides precise braking control and quick system response. The system is pressure proportioned, front to rear, for improved slippery road control.

The Hitachi wet disc brake is engineered for long service life, even in the most extreme environments. The wet disc brakes are located on the rear axle and provide service braking and secondary braking functions. The brakes are of a multi-plate design and continuously oil-cooled.

Front Axle - Dry Disc

Disc Diameter Each (2 discs/axle)	132.0 cm	(52 in)
Brake Surface Area Per Axle	18 548 cm ²	(2 874 in ²)
Lining Area Per Axle	6 194 cm ²	(960 in ²)
Brake Pressure (Max.)	20 700 kPa	(3 000 psi)

Rear Axle - Oil-Cooled Wet Disc

Brake Surface Area Per Axle	180 741 cm ²	(28 015 in ²)
Brake Pressure (Max.)	15 860 kPa	(2 300 psi)

Secondary

Dual independent hydraulic circuits within the service brake system provide fully modulated reserve braking capability. Both front dry disc and rear wet disc are automatically applied when loss of pressure is detected.

Parking

Four spring on, hydraulic off armature disc brake heads provide parking capabilities. The braking system complies with J/ISO 3450.

Retarder

Superior retardation to zero speed on grades is achieved through AC wheel motors in conjunction with the Siemens resistor grid package. A recessed grid box, located on the service deck, enhances operator visibility. Cooling for the grid package is achieved with forced air flow provided by a blower driven by a single electric motor.

Maximum dynamic retarding with continuous rated blown grids:		
Standard	3 508 kW	(4 704 HP)

Load/Dump Brake Apply

Through activation of a switch by the operator, a solenoid is energized, sending full brake pressure to apply the rear Wet Disc brakes. For use during the load and dump cycles.



COMMAND CAB II

Monitoring System

CONTRONIC II monitors and diagnoses all onboard systems including Siemens drive system and engine. Data links offer complete integration, while a single multi-language Liquid Crystal Display (LCD) clearly details machine functions. Downtime is minimized with faster and more reliable troubleshooting and analysis.

HAULTRONIC II load weighing system offers benefits such as better equipment utilization on the jobsite, accurate unit and fleet production results, and benchmark unit statistics against fleet results. Cycle time, distance and cycle count can all be measured and recorded to further improve job productivity. HAULTRONIC II is fully integrated with CONTRONIC II vehicle monitoring system and display interface, avoiding potential failure or error common in aftermarket systems.

Excellent Serviceability

A removable front closure allows easy access to the service brake valve and heater connections. The upper dash utilizes four (4) removable panels that house gauges and customer options, each individually accessible. A removable closure located behind the seat provides easy access to the shifting control, CONTRONIC II, and all electrical junction points.

Comfort and Ease of Operation

A wrap-around style dashboard positions controls within easy reach and visual contact. A full complement of easy-to-read gauges, CONTRONIC II monitoring and warning system, a spacious environment, six-way adjustable air seat, tilt/telescopic steering wheel, filtered ventilation, door locks, and a full size trainer seat, all contribute to operator safety and comfort.



SUSPENSION

Front and Rear Suspension

For years, Hitachi haulers have enjoyed an industry-wide reputation for superior suspension systems. That experience and knowledge has now been elevated to the next level, to develop the truly advanced ACCU-TRAC suspension for the EH5000.

The new ACCU-TRAC suspension system features independent trailing arms for each front wheel with NEOCON struts, containing energy absorbing gas and compressible NEOCON-E™ fluid, mounted between the king pins and the frame. This arrangement allows a wider front track that provides a better ride, improved stability and a reduced turning circle. The rear NEOCON struts are mounted in a more vertical position which allows a more pure axial loading and reduces the tractive and braking forces transmitted to the nose cone.

Hitachi NEOCON struts outperform competitive strut designs by improving isolation, stability, and control. Improved isolation means reduced impact loading on the structural members of the machine and greater operator comfort, resulting in longer equipment life and productivity. Improved stability means more consistent dynamic response of the machine to fluctuating load energy, resulting in predictable machine performance. Improved control also means better machine maneuverability.

The Hitachi frame and ACCU-TRAC suspension system are designed to work in unison to provide maximum structural integrity and operator comfort. The fabricated rectangular frame rail construction provides superior resistance to bending and torsional loads while eliminating unnecessary weight. The unique ACCU-TRAC independent trailing arm suspension absorbs haul road input, minimizing suspension-induced frame twisting while providing independent tire action. NEOCON ride struts are mounted with spherical bushings, eliminating extreme sidewall forces by ensuring a purely axial input to the ride strut. The wide track stance of the ACCU-TRAC suspension system and the long wheel base assure a more stable, comfortable ride.

Specifications: EH5000



FRAME

Full fabricated box section main rails with section height tapered from rear to front. Wider at the rear to support the loads and narrower at the front to allow for engine accessibility. One piece top and bottom flanges that eliminate cross member tie in joints and provide a large exposed center area for access to major components. Large radii minimize stress concentrations. Welded joints are oriented longitudinally to the principal flow of stress for greater durability and more strength. Frame utilizes 345 N/mm² (50 000 psi) yield strength alloy steel that is robotically welded to ensure high quality welds. Superior design, robot welding and ultrasonic testing using state-of-the-art technology produces "Euc Tough" frames that minimize castings and vertical welds to better accept all stresses. Zero plug-in joints ensure maximum frame strength.



BODY

Flat chute type, sloped floor, continuously exhaust-heated. Extended canopy protects service deck area. High tensile strength 400 BHN abrasion resistant alloy steel is used in thicknesses of:

	mm	(in)
Floor	19	(0.75)
Front	13	(0.5)
Sides	13	(0.5)
Canopy	6	(0.25)
Corners	19	(0.75)

High strength 690 N/mm² (100 000 psi) alloy steel is also used for the canopy side members and floor stiffeners. The body is rubber cushioned on the frame.

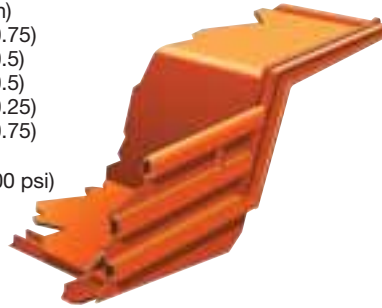

SERVICE CAPACITIES

	L	(US gal)
Accumulator	76.0	(20.0)
Crankcase (includes filters)		
Detroit Diesel 16V-4000	242.0	(64.0)
Cummins QSK60-L	265.0	(70.0)
Cooling System		
Detroit Diesel 16V-4000	697.0	(184.0)
Cummins QSK60-L	643.0	(170.0)
Fuel Tank	3 785	(1 000)
Hydraulics		
Hoist System	965.0	(255.0)
Steering System	291.0	(77.0)
Hitachi Planetary Drives	223.0	(59.0)
Front Wheels	27.0	(7.0)
Windshield Washer	7.6	(2.0)

Performance Data: EH5000

EH5000 RIMPULL CHART

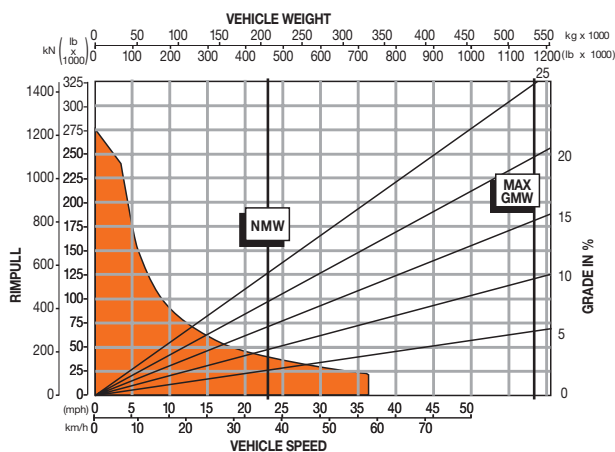

EH5000 RETARDER CHART

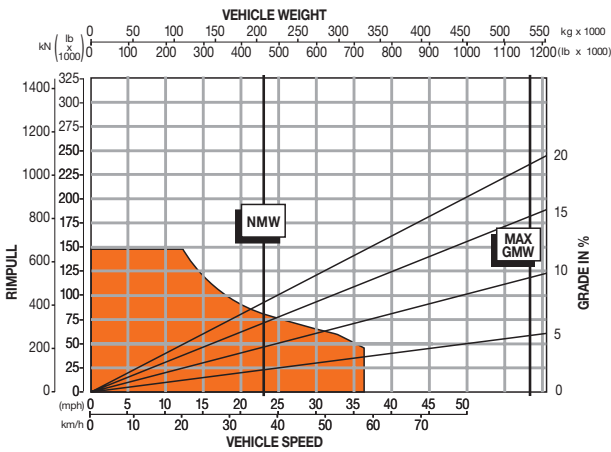

NOTES:

Diagonal lines represent total resistance (Grade % plus rolling resistance %). Charts based on 0% rolling resistance, standard power of engine, standard tires and gearing unless otherwise stated.

1. Find the total resistance on diagonal lines on right-hand border of rimpull or retarder chart.
2. Follow the diagonal line downward and intersect the NMW or GMW weight line.
3. From intersection, read horizontally right or left to intersect the rimpull or retarder curve.
4. Read down for machine speed.

Equipment & Dimensions: EH5000

STANDARD EQUIPMENT

GENERAL

Access ladders
Air conditioning
Air cleaner protection
All-hydraulic braking
Automatic lubrication system
Battery box, ground level
Battery isolation switch
Body down indicator, mechanical
Body prop pins
Centralized service panel
Continuously heated body
Cruise control, propel/retard
Electric horn, dual
Electric hoist control
Electric start
Engine access ladders (2)
Engine self load test
Extended body canopy
Fan guard
Fast fueling system, on tank
Fuel gauge on tank
Ground level engine shutdown switch
Guard rails around platform

HAULTRONIC II load weighing system
HID headlights
Hoist kickout
Ladder lights
Mirrors, right and left
Mud flaps
NEOCON suspension struts
Operator arm and grid box guards
Propulsion interlock, body up
Radiator grille guard
Retard speed control
Retarder grid package, 16-element
Reverse alarm
Rock ejector bars
Supplementary steering system, accumulator
Thermatic fan
Tow hooks, front and rear
Wiggins fast fueling

CAB

Acoustical lining
Air filtration/replaceable element
Air suspension seat, 6-position
Ash tray
Auxiliary outlet, 12-volt
Cab interior light
Cigar lighter
Door locks
Engine starter/shutdown switch
Full trainer seat
Heater and defroster 26,000 Btu
Integral ROPS/FOPS cab
ISO driver envelope

Load and hold switch
Modular instrumentation
Operator seat belt
Roll down windows
Rubber floor mat
Safety glass
Sun visor
Tilt/telescopic steering
Tinted glass all windows
Trainer seat belt
Windshield washer
Windshield wiper

GAUGES AND INDICATORS

CONTRONIC II monitoring and alarm system, multi-function indicator lights:

Air filter restriction
Alternator
Body up indicator
Blower loss
Brake supply pressure
Brake temperature
Central warning
Engine oil pressure
Engine coolant temperature
High beam indicator
Hoist filter restriction
Hoist oil temperature
Hoist supply pressure
Parking brake applied
Payload monitoring
Steering filter restriction
Steering oil temperature
Traction system fault

Turn signals/hazard
Wheel motor temperature
Gauges:
Brake temperature
Engine coolant temperature
Fuel gauge in cab (LCD)
HAULTRONIC II
Hourmeter (LCD)
Speedometer
Steer/brake supply pressure
Steer accumulator pre-charge (LCD) gauge
Tachometer
Voltmeter (LCD)
Wheel motor temperature

MACHINE LIGHTS

Back-up light, (2)
Clearance lights, LED (4)
Dual combination stop and tail lights, LED (2)
Dynamic retarding light, LED (1)
Engine compartment lights, (2)
HID headlights, (4)
Payload monitoring lights, LED
Rear axle light, (1)
Turn signals and four-way flashers

OPTIONAL EQUIPMENT

Ansul centralized fire extinguishing system (16 nozzle)
Auxiliary dump
Auxiliary steer
Battery box, on deck
Body liners (400 BHN)
Body side extensions
Cab, acoustic package
Canopy spillguard extension (12" total)

Engine coolant and oil heater (220 V AC)
Keyless starter switch
Loadweight displays
Mufflers
Trolley assist configuration

Standard and optional equipment may vary from country to country. Special options provided on request. All specifications are subject to change without notice.

Note: Dimensions shown are for empty machine with 53/80 R63 tires.

unit:mm
(ft in)

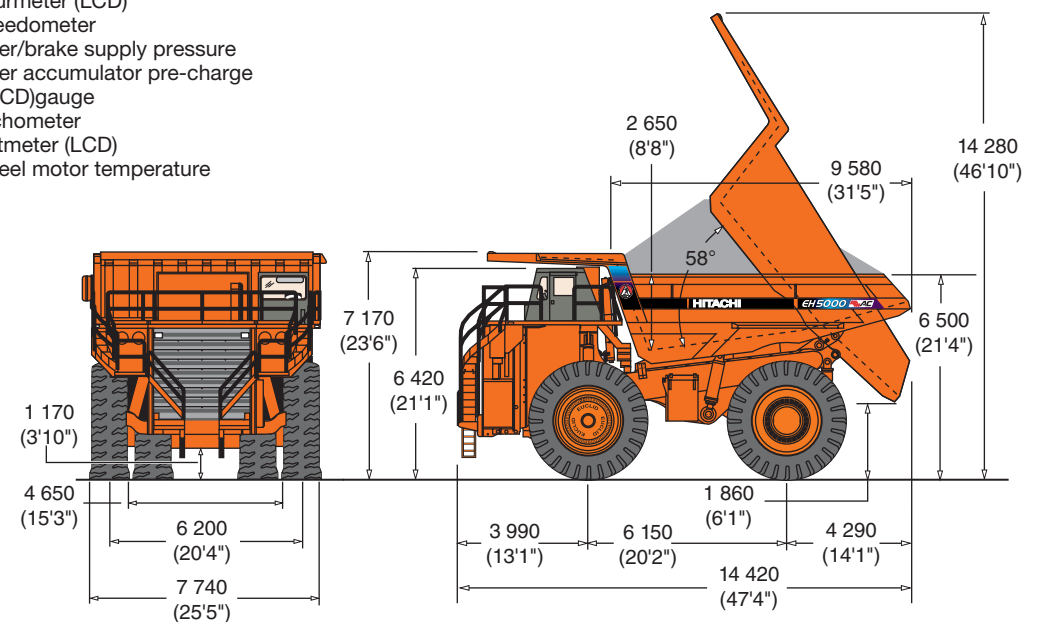
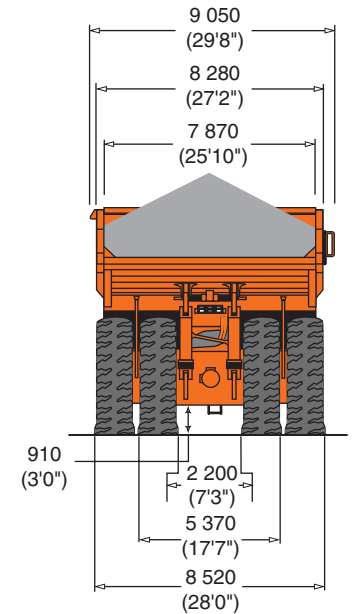

EH5000

 **Hitachi Construction Machinery Co., Ltd.**

Head Office : 5-1, Koraku 2-chome, Bunkyo-ku
Tokyo 112-8563, Japan
Telephone : 81-3-3830-8050
Facsimile : 81-3-3830-8204
URL : www.hitachi-c-m.com

These specifications are subject to change without notice.
Illustrations and photos show the standard models, and may or may not include optional equipment, accessories, and all standard equipment.
Before use, read and understand Operator's Manual for proper operation.